

Varian Vacuum Technologies
121 Hartwell Avenue
Lexington, Massachusetts 02421
(781)861-7200

Multi-Gauge Controller

Part No. L8350301

Instruction Manual



VARIAN

Manual No. 6999-08-091
Revision W
February 2001

Telephone Numbers

U.S. only 1-800-8-VARIAN (1-800-882-7426)

From Alaska and Hawaii, dial (781) 861-7200

Order Entry (Sales).....Press 1FAX (781)860-5405
Technical Support.....Press 2FAX (781)860-5465
Field Service.....Press 3FAX (781)860-9210
Training (Information
and Registration).....Press 4FAX (781)860-5479

Service

Canada

Telephone1-800-663-2727 (Canada Only)
(905) 819-8188
FAX(905) 819-8348

France

Telephone(33) 16-986-3838
FAX(33) 16-928-2308

Germany (Darmstadt)

Telephone(49) 61-51-70-32-05
FAX(49) 61-51-70-32-79

Germany (Hamburg)

Telephone(49) 40-669-60-33
FAX(49) 40-668-22-82

Italy

Telephone(39) 11-997-9111
FAX(39) 11-997-9350

Japan

Telephone(81) 3-3588-9732
FAX(81) 3-3449-4597

Korea

Telephone(82) 3-333-665-5171
FAX(82) 3-333-665-0115

UK

Telephone(44) 932-234-741
FAX(44) 932-228-769

Copyright © by Varian Associates, Inc.
Reserved, including the right of reproduction in whole or in part in any form, without
permission in writing from Varian Vacuum Products, Lexington, MA 02173

WARRANTY

Products manufactured by Seller are warranted against defects in materials and workmanship for twelve (12) months from date of shipment thereof to Customer, and Seller's liability under valid warranty claims is limited, at the option of Seller, to repair, replacement, or refund of an equitable portion of the purchase price of the Product. Items expendable in normal use are not covered by this warranty. All warranty replacement or repair of parts shall be limited to equipment malfunctions which, in the sole opinion of Seller, are due or traceable to defects in original materials or workmanship. All obligations of Seller under this warranty shall cease in the event of abuse, accident, alteration, misuse, or neglect of the equipment. In-warranty repaired or replacement parts are warranted only for the remaining unexpired portion of the original warranty period applicable to the repaired or replaced parts. After expiration of the applicable warranty period, Customer shall be charged at the then current prices for parts, labor, and transportation.

Reasonable care must be used to avoid hazards. Seller expressly disclaims responsibility for loss or damage caused by use of its Products other than in accordance with proper operating procedures.

When products are used with toxic chemicals, or in an atmosphere that is dangerous to the health of humans, or is environmentally unsafe, it will be the responsibility of the Customer to have the product cleaned by an independent agency skilled and approved in handling and cleaning contaminated materials before the product will be accepted by Varian Associates for repair and/or replacement.

Except as stated herein, Seller makes no warranty, express or implied (either in fact or by operation of law), statutory or otherwise; and, except as stated herein, Seller shall have no liability under any warranty, express or implied (either in fact or by operation of law), statutory or otherwise. Statements made by any person, including representatives of Seller, which are inconsistent or in conflict with the terms of this warranty shall not be binding upon Seller unless reduced to writing and approved by an officer of Seller.

Warranty Replacement and Adjustment

All claims under warranty must be made promptly after occurrence of circumstances giving rise thereto, and must be received within the applicable warranty period by Seller or its authorized representative. Such claims should include the Product serial number, the date of shipment, and a full description of the circumstances giving rise to the claim. Before any Products are returned for repair and/or adjustment, written authorization from Seller or its authorized representative for the return and instructions as to how and where these Products should be returned must be obtained. Any Product returned to Seller for examination shall be prepaid via the means of transportation indicated as acceptable by Seller. Seller reserves the right to reject any warranty claim not promptly reported and any warranty claim on any item that has been altered or has been returned by non-acceptable means of transportation. When any Product is returned for examination and inspection, or for any other reason, Customer shall be responsible for all damage resulting from improper packing or handling, and for loss in transit, notwithstanding any defect or non-conformity in the Product, in all cases, Seller has the sole responsibility for determining the cause and nature of failure, and Seller's determination with regard thereto shall be final.

If it is found that Seller's Product has been returned without cause and is still serviceable, Customer will be notified and the Product returned at its expense; in addition, a charge for testing and examination may be made on Products so returned.

Hazards

Operators and service personnel must be aware of all hazards associated with this equipment. They must know how to recognize hazardous and potentially hazardous conditions, and know how to avoid them. The consequences of unskilled, improper, or careless operation of the equipment can be serious. This product must only be operated and maintained by trained personnel. Every operator or service person must read and thoroughly understand operation/maintenance manuals and any additional information provided by Varian Associates. All warnings and cautions should be read carefully and strictly observed. Consult local, state, and national agencies regarding specific requirements and regulations. Address any safety, operation, and/or maintenance questions to your nearest Varian office.

The following format is used in this manual to call attention to hazards.



WARNING

Warnings are used when failure to observe instructions or precautions could result in injury or death.



CAUTION

Cautions are used when failure to observe instructions could result in damage to equipment, whether Varian supplied or other associated equipment.



NOTE

Notes contain information to aid the operator in obtaining the best performance from the equipment.



WARNING



Check that your Ion Gauge Controller and vacuum system are **separately** grounded to a common ground.

Placement of a ground wire between the vacuum chamber and the controller chassis is **not safe**; large continuous currents could flow through it.

Personnel could be killed by high voltages (160 to 900 volts may be present in an improperly grounded system).

Make absolutely sure that your vacuum system is grounded as shown in the following schematic diagram; test the system ground to be sure that it is complete and capable of supporting at least 10 amperes.

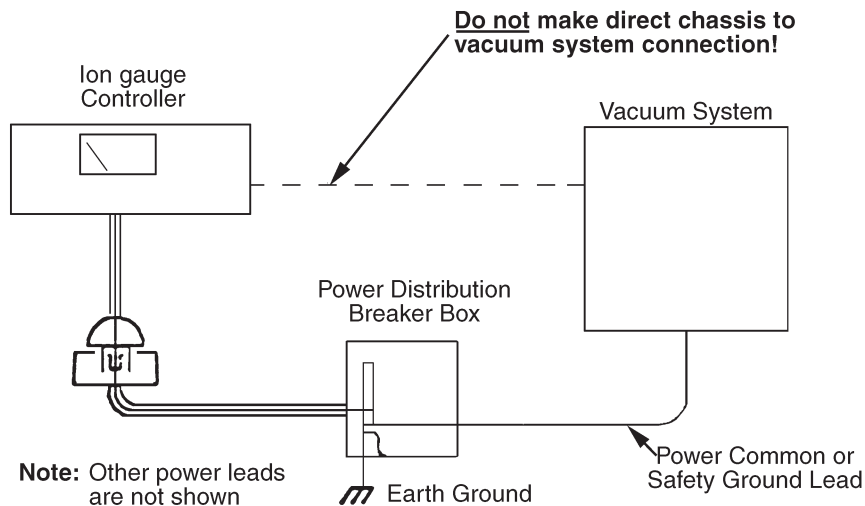

An independent agency has determined that **all** vacuum chambers, regardless of manufacture, can possibly become charged to lethal voltage levels, under certain conditions, if they are not grounded with a quality, common ground with the controller of their ionization tube. After each maintenance/ service procedure and before operating the controller and vacuum system, verify the integrity of the ground of both units. **Failure to do so could cost you your life!**



WARNING

This equipment contains high voltages (up to 3000 volts), high enough to produce electric shock and cause death or serious injury.

Equipment utilizing these controls should be designed to prevent personal contact with high voltages.

Always break the primary circuit when direct access to the control unit is required



NOTE

This equipment has been tested and found to comply with the limits for a Class A digital device, pursuant to Part 15 of the FCC rules. These limits are designed to provide reasonable protection against harmful interference when the equipment is operated in a commercial environment. This equipment generates, uses, and can radiate radio frequency energy and, if not installed and used in accordance with the instruction manual, may cause harmful interference to radio communications. Operation of this equipment in a residential area is also likely to cause harmful radio communications interference in which case the user will be required to correct the interference at his own expense.

Table of Contents

	Page
I INTRODUCTION AND DESCRIPTION	1-1
1-1 General	1-1
1-2 Specifications	1-1
1-3 Optional Printed Circuit Cards	1-1
1-4 Description of Display	1-2
1-5 Description of Controls	1-2
II PREPARATION FOR USE	2-1
2-1 Unpacking	2-1
2-2 Installation	2-1
III OPERATING INSTRUCTIONS	3-1
3-1 General	3-1
3-2 Display	3-1
3-3 Keyboard	3-1
3-4 Setting Parameters	3-4
3-5 Operation	3-4
3-6 Battery Backup	3-5
3-7 Access Codes	3-5
IV TROUBLESHOOTING	4-1
4-1 General	4-1
4-2 Keyboard Commands	4-1
4-3 Error Codes	4-1
4-4 Changing Line Fuses	4-2
4-5 Changing the PROM	4-3
Appendix A, Gas Correction Factor Table	A-1
Appendix B, UHV Board, Part No. L8321301	B-1
Appendix C, Thermocouple Board, Part No. L6430301	C-1
Appendix D, Bayard-Alpert Board, Part No. L6427301	D-1
Appendix E, Cold Cathode Board, Part No. L6433301	E-1
Appendix F, Remote I/O Board, Part No. L8324301	F-1
Appendix G, Set Point Board, Part No. L8327301, L8727302	G-1
Appendix H, Capacitance Diaphragm Board, Part No. L6491301	H-1
Appendix J, Convector Board, Part No. L6496301	J-1
Appendix K, Inverted Magnetron Board, Part No. L69066301	K-1
Appendix L, Convector Board, Part No. L9887301	L-1
Appendix M, RS232 and RS422/485 Boards and ASCII Protocol	M-1

List of Illustrations

	Page
1-1 Multi-Gauge Front Panel with Fully Lighted Display	1-3
2-1 Setting Line Voltage	2-2
2-2 Installing the Option Cards and the Spacer/Retainer	2-3
3-1 Multi-Gauge Display	3-1
3-2 Multi-Gauge Front Panel Showing Keyboard	3-2
4-1 Straightening the Pins	4-3
4-2 Location of Chip and Socket Notches	4-3
4-3 Installing the Chip	4-3

SECTION I

INTRODUCTION AND DESCRIPTION

1-1 GENERAL

Varian's Multi-Gauge is a half-rack, modular vacuum gauge controller offering unprecedented flexibility. Due to its advanced design, the user can add or change gauging and process control capability, in the field, by simply inserting or removing option boards.

With Multi-Gauge, it is possible to operate up to three ion gauges and eight thermocouple gauges simultaneously or, with fewer gauges, to add process control options such as setpoints or Remote I/O.

1-2 SPECIFICATIONS

Power Requirements	90 to 127 VAC, 50/60 Hz 208 to 250 VAC, 50/60 Hz The Multi-Gauge is fitted with an internal switch to accommodate the desired power input.
Operating Temperature	0 to 50°C The Multi-Gauge meets all performance specifications (unless otherwise noted) at 25°C ($\pm 5^\circ\text{C}$) and 90 percent relative humidity, non-condensing.
Data Retention	The Multi-Gauge will retain its parameter values, upon power down or a power failure, for a period of four years accumulated off-time.
Size	Half-rack mount – 3.5" high by 8.0" wide by 15" deep Optional rack-mounting kits are available for mounting one or two units in a standard 19-inch rack.
Cabling	The Multi-Gauge basic unit includes an 8-foot, U.S. standard, power cord and fuse set. Gauge cabling is not included. Power cords for other areas of the world are available upon request from Varian Vacuum Products.

1-3 OPTIONAL PRINTED CIRCUIT BOARDS

Up to five optional printed circuit boards can be user-installed in the mother board of the Multi-Gauge basic unit with the following restrictions:

- up to three "high-profile" boards, consisting of Bayard/Alpert, UHV, inverted magnetron, cold cathode and capacitance diaphragm boards, with a limit of two capacitance diaphragm boards (each board runs two heads)
- up to two TC boards
- two ConvecTorr boards (two Convectorr gauges/board, total 4 maximum)
- one setpoint board
- one manual I/O board
- other boards as they become available

RS232 Option

The RS232 option is available via a plug-in printed circuit board with a standard 9-pin “D” connector (Varian part no. L6439301) or with fiber optic connectors (Varian part no. L6449301). It allows complete operation of the Multi-Gauge via a computer using serial communication. All of the keypad functions (except for the baud rate setting and the display output) are accessible through the RS232 bi-directional computer link. Refer to the RS232 instruction manual (Varian Part No. 699908130) for a further description of the RS232 option.

The RS485/422 Communications Interface option is available as a plug-in printed circuit board (Varian part no. L8940301). This option provides serial communications capability as specified in Electronics Industry Association (EIA) Standard 422 and 485. Both employ differential line drivers and receivers and are capable of communicating to distances of 4000 feet at 19,200 baud in multi-drop scheme and operate up to 32 Multi-Gauge units. Refer to the RS485/422 instruction manual (Varian part no. 6999-08-175 for a description of the RS485/422 option.

Card Slot Location

Neither of the Communications Interfaces use any of the five card slot locations designed for other transducer cards. The communications slot is a stand-alone location. It exists solely for the purpose of supporting communications.



NOTE

Multi-Gauge units manufactured before February 1st, 1994, required a ribbon cable connector for RS232 communications. All units manufactured after this date are operated with board level communication cards; the ribbon connectors are no longer required. However, the board level RS232 is compatible with all units, regardless of the manufacturing date.

1-4 DESCRIPTION OF DISPLAY

The front panel display of the Multi-Gauge is a backlit, custom color, liquid crystal display readable in a dark room or under typical laboratory light. It has a viewing angle of $\pm 45^\circ$ with a bias toward looking down.

The display features a 15-segment TC bar graph that ranges from 10^{-3} Torr to atmosphere, a three-digit mantissa (a fourth digit is available via the computer interface or when the expanded scale is enabled), a $\pm 1\frac{1}{2}$ digit exponent, and various annunciators that display the pressure units and the emission, degas, and setpoint status, among other features.

The display is dead front when the segments (annunciators) are off.

1-5 DESCRIPTION OF CONTROLS

On the right-hand side of the front panel is a 12-key membrane keypad used to control the functions of the Multi-Gauge; the resultant readings are displayed on the large, easy-to-read display next to the switches (see Figure 1-1).

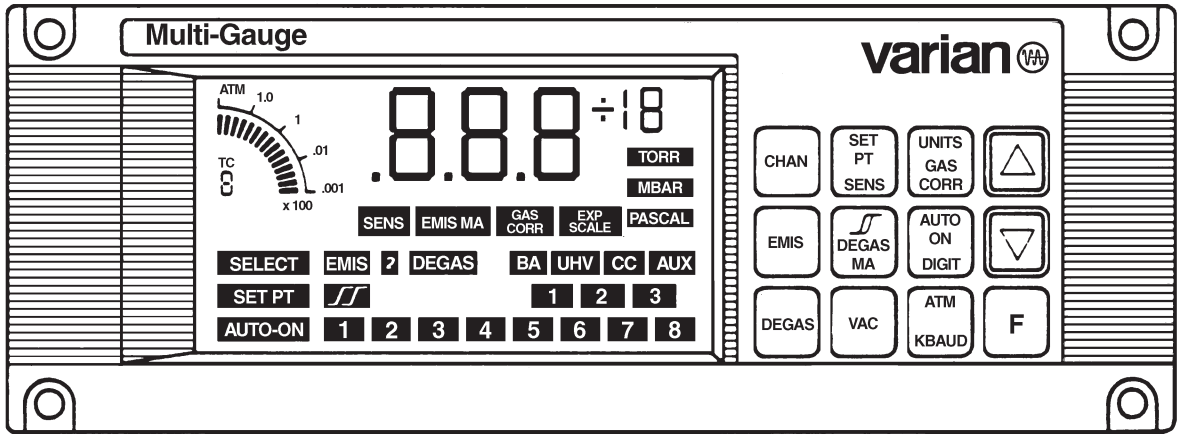

Figure 1-1. Multi-Gauge Front Panel with Fully Lit Display

SECTION II

PREPARATION FOR USE

2-1 UNPACKING

Each Multi-Gauge unit is inspected and carefully packed prior to shipment. If the unit arrives damaged, save the packing materials and immediately notify the carrier. Because the packing materials are designed specifically for this instrument, they should always be used when transporting the unit. The shipping container is packed with the following contents.

1 ea Multi-Gauge Basic Unit	4 ea blank filler plates
1 ea A-C line cord	1 ea board spacer/retainer
1 ea Operating Manual	4 ea rubber adhesive feet

The unit is shipped with switch S1 (internal) set to 230 VAC.

2-2 INSTALLATION

Before operating the unit, it is necessary to set it for the proper line voltage level and install any optional printed circuit boards.



WARNING

Before servicing the unit, check that the line cord is not plugged into a power source. Observe all Warnings and Cautions printed on the cover.

- 1 Open the unit by removing the two screws at the top rear of the unit then pivot the cover up and back to disengage the front lip. Lift off the cover.
- 2 Set the line voltage by moving switch S1 to either the 115V (for 110V or 115V, 50/60 Hz) or 230V position (for 220V or 240V, 50/60 Hz) as shown in Figure 2-1.
- 3 Install the optional printed circuit boards by plugging them into any or all of the five board slots as shown in Figure 2-2. Although the boards can be inserted in any slot, Varian recommends that high-profile boards (those whose components are greater than $\frac{3}{4}$ inch tall) are plugged into the three more widely spaced slots. This will allow installation of a full complement of boards as well as make future upgrades easy.
- 4 After the optional printed circuit boards are installed, place a blank filler plate in any open rear panel locations. Identify each board with a board identifier label (provided with each board) on the back of the unit.
- 5 If more than one full-length board is plugged in, press the printed circuit board spacer/retainer onto the top edge of the boards as shown in Figure 2-2. This will prevent the boards from touching one another and will hold them securely in the unit when the cover is in place. The spacer is not to be used if only one full-length board is plugged in.

Preparation for Use

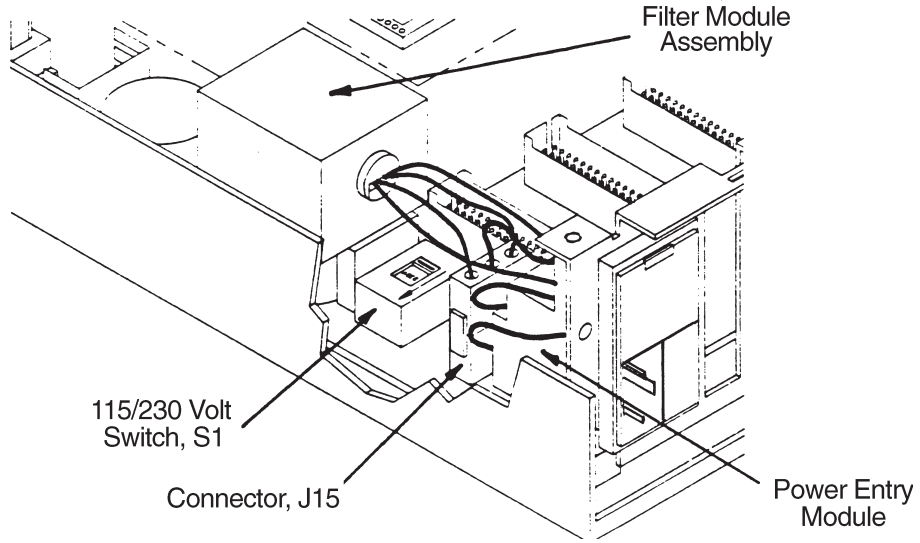

Figure 2-1. Setting Line Voltage

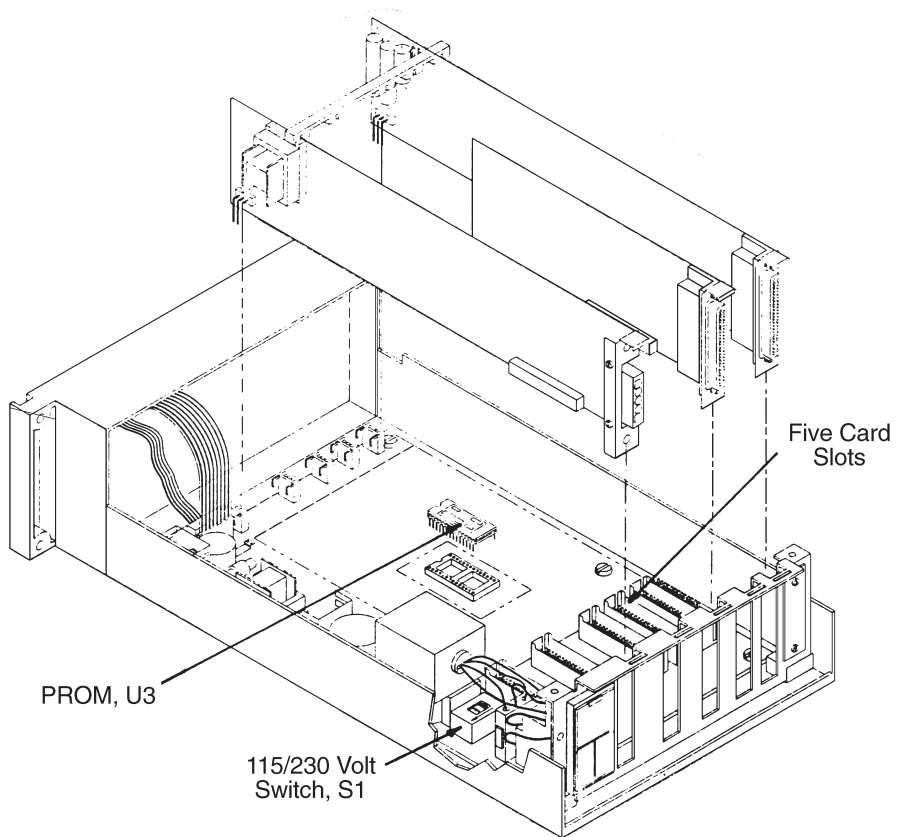

Figure 2-2. Installing the Option Boards and the Spacer/Retainer

Preparation for Use

- 6 Before replacing the top cover, check that the line voltage selector S1 is correctly positioned, that all boards are properly seated and not touching each other, all cables are properly plugged in, and that there is no loose hardware or metal parts inside the Multi-gauge unit. Replace the cover and secure it with two screws.
- 7 Mount the unit using the desired rack-mounting kit, then attach the appropriate external gauge and system cables.



NOTE

For optimum visibility, Varian recommends that the unit be mounted at or below eye level.

SECTION III

OPERATING INSTRUCTIONS

3-1 GENERAL

Multi-Gauge offers an extraordinary amount of gauging and programming capability while still being easy to use. Except for the power switch on the rear panel, the operator can access all of the instrument's functions and parameters through the front panel keyboard. The pressure readings and various prompts and annunciators are presented on the liquid crystal display.

3-2 DISPLAY

The display employs four colors to organize the data (Figure 3-1).

- Green for data
- Yellow for data labels (or modifiers)
- Red for operational status; setpoints
- Blue for primary measurement gauge identifiers

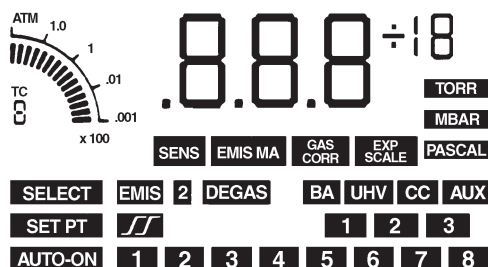
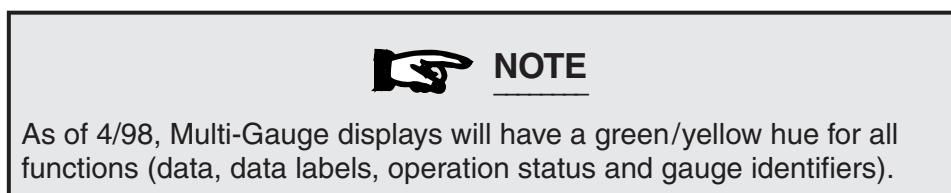

Figure 3-1. Multi-Gauge Display

3-3 KEYBOARD

The keyboard is a sealed membrane-type with tactile feedback. There are twelve keys, some of which are dual-function (Figure 3-2). A description of each key function and display response follows. Note that some of the keys may not work unless a particular option board has been installed. Also, the actual workings of the key may depend upon the specific gauge or board involved. In all cases, the operator should refer to that section in the manual for more detailed information.

1. CHAN
 - a. Selects the data channel to be displayed or programmed.
 - b. The gauge selected is identified by the blue annunciators or, if none are lit, by the TC identifier number. In the case of multiple boards of the same type, the leftmost board, as viewed from the front of the panel, is identified as number 1.
 - c. Pressing the key scrolls through the channels in sequence.

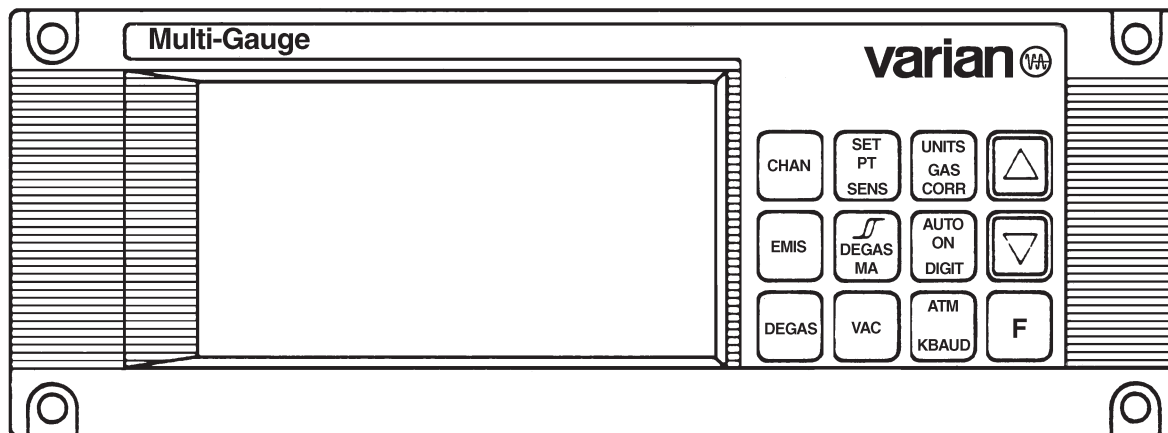

Figure 3-2. Multi-Gauge Front Panel Showing Keyboard

2. EMIS

- a. On the B/A and UHV boards, a keypad function to light the second filament has been added. The sequence [F] [EMIS] will turn on filament 2 from the OFF state. [EMIS] is still used to turn off the emission.
- b. Turns on/off the emission current for the selected gauge.
- c. The red EMIS legend lights when activated.
- d. A red “2” will light next to the EMIS display if the instrument has activated a second filament.

3. DEGAS

- a. Turns on/off the degas supply for the selected gauge.
- b. The red DEGAS legend lights when activated. Note that only one ion gauge can be in degas, the emission must be on, and the pressure must be less than 1×10^{-5} Torr.
Note: The UHV board will not display a pressure during degas, “- -”.

4. SETPT

Used to program or display the setpoint data. Requires the setpoint board to operate.

5. \int (HYSTERESIS)

Used in conjunction with the setpoint key to program or display the setpoint hysteresis data.

6. F SENS

This is the second function of this key and is used to display and program the gauge sensitivity factor. Any value between 0.1 to 99.9 per Torr can be input if desired. Multi-Gauge will assign, as a default, the nominal sensitivity factor as specified in the applicable gauge section. In the case of the Capacitance Diaphragm Board, this function selects the full-scale reading of the gauge head, ranging from 0.1 to 1000 Torr. The default is 10 Torr.

7. F EMIS mA

This is the second function of this key and is used to display and program the gauge emission current, if applicable. Any value between 0.01 to 9.99 mA, in increments of 0.01 mA, can be programmed.

Multi-Gauge will assign, as a default, the nominal emission currents as specified in the applicable gauge section.

8. UNITS

This key is used to select the units of pressure for all gauge readouts. Torr, mbar, and Pascal can be selected.

9. F GAS CORR

This key is used to display and program the gas correction factor, if applicable, for the selected gauge. Any value between 0.01 and 9.99 can be programmed. Entering a value other than the default of 1.00 (N₂) will light the GAS CORR annunciator on the display.

10. AUTO-ON

This key is used to select and program a thermocouple gauge to automatically turn on an ion gauge. This function requires one of the following to be installed; thermocouple, ConvecTorr or a ConvecTron board. the ionization gauge channel must be selected first; pressing the auto-on key will scroll through TC channels 1 to 8.



NOTE

Normally, Auto-on should not be set lower than 5 mT when using a thermal gauge (TC or ConvecTorr) as the reference.

11. F DIGIT

This key allows the operator to select either one or two decimal places or an expanded scale of three decimal places. In the expanded scale, the EXP SCALE annunciator light on the display will be lit to indicate that the most significant digit of the mantissa is not visible.

12. VAC

This key is used to adjust the vacuum reading for applicable gauges (for example, thermocouples). VAC calibration range $9.90 \cdot 10^{-2}$ to $1.00 \cdot 10^{-3}$, default $1.00 \cdot 10^{-3}$ for high vacuum.

13. ATM

When pressed, this key is used to cause the display to read atmosphere for applicable gauges (for example, thermocouples).

14. F KBAUD

This function is used to display and program the RS232 baud rate and parity.

15. \triangle (UP arrow)

This key is used to increment digits when entering parameters. It also increments the thermocouple displayed on the bargraph when the main display shows a primary measurement gauge.

16. ∇ (DOWN arrow)

This key is used to decrement digits when entering parameters. It also decrements the thermocouple displayed on the bargraph when the main display shows a primary measurement gauge.

17. F

This key, when pressed ahead of other specific keys, is used as a prefix stroke to select the second function of those specific keys.

3-4 SETTING PARAMETERS

When programming the Multi-Gauge, it may be necessary to set values for the various system parameters (e.g., sensitivity, gas correction, setpoints, etc). The following procedure is used, regardless of the parameter being programmed.

- a. Select the function by pressing the appropriate key or keys.
- b. The display will show the present value of the parameter with the left-most digit flashing and the appropriate annunciator lit.
- c. To change the value of the digit, if necessary, press the up or down arrow until the desired value is reached. Wait several seconds; the next digit to the right will begin flashing.
- d. Change the digit using the up or down arrows, as desired.
- e. Continue until all digits have been set.
- f. The display will revert back to reading pressure after several seconds.

 **NOTE**

- If an illegal entry is attempted (such as 0.00 for sensitivity, for example), the display will show “Err”, followed by the default value for that parameter. The default value will be applied until the operator re-programs the parameter correctly.
- During the digit-setting procedure, the red F key can be pressed to advance from one flashing digit to the next. The F key can also be held to fast-forward to the end of the procedure. This allows the operator to view the setting and quickly exit the routine.

3-5 OPERATION

Refer to Section II for unpacking and installation instructions, if necessary.

Turn on the POWER switch on the rear panel and watch the display on the front panel. This display indicates the type of printed circuit board installed in the left-most position in the Multi-Gauge as viewed from the front. Either one of the four blue gauge identifiers (UHV, BA, CC, or AUX) will be lit along with a blue “1” or, if none are lit, the yellow TC identifier will be lit along with a green “1”.

Press the CHAN key. The gauge identifier should change to reflect the boards installed in the unit. If more than one of the same boards are installed, the gauge number will change to “2” or “3”, as required, retaining the same gauge type (UHV 1, UHV 2, BA1, BA2, etc.). In the event that no identifiers are lit, or they do not match the type of board installed in the Multi-Gauge, refer to Section IV, Troubleshooting.

To operate the Multi-Gauge, press the CHAN key to select the desired channel. Press the proper key to activate the desired function. For example, to assign and program set points for UHV2, scroll through the gauges using the CHAN key until the blue “UHV2” legend appears on the front panel. Press the SETPT key. Any set points you now program will be assigned to trigger from the UHV2

board. This applies to all other functions as well as turning the gauge emission on and off. Whenever a function is selected or activated, it will apply only to the gauge channel indicated by the blue identifiers or the "TC" identifier if no blue identifiers are lit. The exceptions are UNITS, DIGIT, and KBAUD, which are common to all channels.

3-6 BATTERY BACKUP

The Multi-Gauge uses a lithium battery and CMOS RAM for storage of all system parameters during power outages or when powered down. Upon restoring power, the Multi-Gauge verifies the RAM contents and, if good, uses the parameters as stored. If an ion gauge was on when power was lost, emission will **not** be automatically re-established unless the TC AUTO ON function was programmed to do so.

Should the RAM be bad, the system resets all parameters to the default values. The RAM will also be reset if the configuration of the unit is changed by adding or removing boards or re-ordering the boards.

3-7 ACCESS CODES

Multi-Gauge offers several "hidden" features available through the keypad. This provides some protection for the operator and the system by requiring knowledge of an access code for the desired function. The access code is entered through the keypad sequence F VAC , using the up and down arrow keys to select the appropriate two-digit code in the same manner as the programmable parameters are set. The functions and their respective codes are:

<i>Function</i>	<i>Code</i>	<i>Description</i>
Lock Keypad	A27	Allows ONLY the CHAN channel select function and the F VAC access code function. Any other keypad function will display the error code E14 for several seconds to show that an illegal keypad entry was made.
Unlock Keypad	A33	Removes keypad lockout and permits any function.
Reset Unit	A81	Resets the Multi-Gauge and returns ALL parameters to their default values, including TC calibration points and programmed setpoints but excluding the RS232 baud rate and parity.
Override E02/E06	A52	IG will ignore pressure bursts and re-light a grid voltage error is detected
Normal Operation	A56	Default mode, normal error code operation

SECTION IV

TROUBLESHOOTING

4-1 GENERAL

These troubleshooting procedures are designed to aid the operator in determining failures to the board level. For further troubleshooting assistance or for the repair or replacement of a board, contact Varian Vacuum Products Service at 1-800-882-7426 or 781-861-7200 within the U.S.

4-2 KEYBOARD COMMANDS

- a. F ↑ Displays the revision of the software in the Multi-Gauge in the format PX.Y
- b. F ↓ Lights all segments on the front panel display for test purposes
- c. F VAC Allows the operator to enter an access code (described in section 3-7).
- d. F CHAN A reverse channel scroll feature which will change the display to the previous channel or gauge.

4-3 ERROR CODES

- a. E01 Indicates an illegal board combination (e.g., no gauge boards, too many gauge boards, or a board developed after the software in use was developed.)
- b. E02 Pressure burst caused by a sudden rise in pressure.
- c. E03 No ion current flow/measurement signal; bad BA-UHV or missing collector cable connection, bad electrometer, emission current too low; cold cathode pressure $< 1 \times 10^{-8}$ Torr
- d. E04 Filament overcurrent (shorted filament circuit)
- e. E05 Filament undercurrent (open filament; cable not connected), bad control board or not installed correctly.
- f. E06 Grid voltage low (grounded grid, bad grid supply, bad EB degas supply)
- g. E07 Overtemperature (temperature inside unit over 65°C). Cause – defective fan.
- h. E08 Board logic failure
- i. E09 Overpressure, indicated pressure above high pressure limit of the ion gauge or capacitance manometer gauge.
- j. E11 Plug-in board power supply failure
- k. E12 Underpressure
- l. E13 Insufficient current
- m. E14 Invalid keypad function (keypad is locked out)
- n. E15 Negative CDG input, beyond VAC range

4-4 CHANGING LINE FUSES



NOTE

For continued protection against fire, both fuses must be replaced with fuses of the same type and rating as originally supplied.

On rare occasions, it may become necessary to change the AC line fuses due to age, overload, etc. There are two fuses which are located on top of the power entry module. The fuses are held by two holders inside the top of the module marked with the outline of the fuses. The fuses can be accessed by prying out the cover of the module with a small screwdriver after removing the power cord.

4-5 CHANGING THE PROM

The PROM (U3) located on the mother board will require replacement whenever the software is upgraded to operate newly-designed option boards or to correct system bugs.



WARNING

Check that the line cord is not plugged into a power source. Observe all Warnings and Cautions printed on the cover.

Removal

- 1 Open the unit by removing the two screws at the top rear of the unit then pivot the cover up and back to disengage the front lip. Lift off the cover.
- 2 It may be necessary to remove some of the printed circuit boards (depending upon how many are installed and the ease of access to the chip) in order to remove the PROM.

Extreme care must be used when removing the chip so as not to damage the mother board. A blank filler plate may be used as a “jack” to remove the PROM. Be sure to pry the PROM up evenly on all sides so as not to bend the pins or damage the socket. A chip extractor (Radio Shack part number 276-1581, or equivalent) may also be used.

Installation

- 1 Straighten the pins on the PROM by holding each side against a flat surface and pressing the pins gently (see Figure 4-1).
- 2 Align the notch on the PROM with the notch in the socket. See Figure 4-2. The notch on the



CAUTION

To protect against damaging electrostatic discharge, follow static preventive procedures (i.e., use a conductive wrist strap) when handling the PROM.

PROM should be installed closest to the front display of the Multi-Gauge unit.

- 3 Check that the notch is closest to the front of the unit and that none of the pins are bent under the chip.
- 4 Align the pins on the chip with the corresponding holes in the socket, then tilt the chip slightly to partially insert one side before the other. See Figure 4-3.

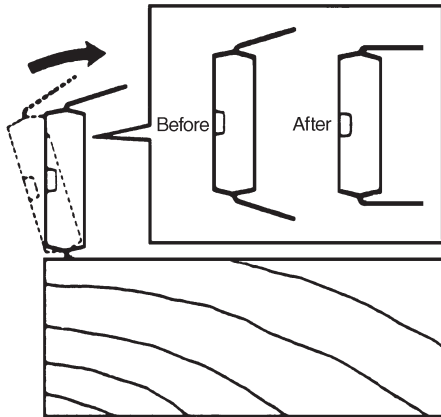

Figure 4-1. Straightening the Pins

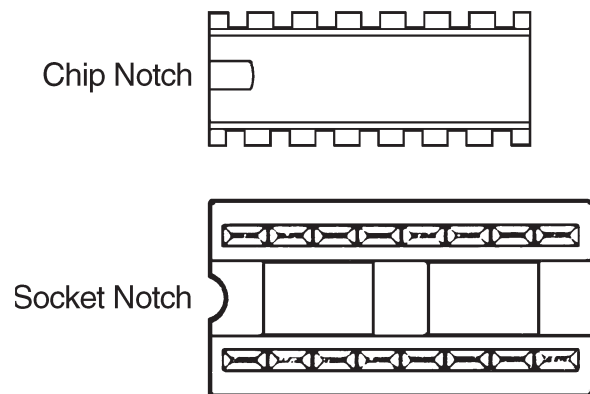

Figure 4-2. Location of Chip and Socket Notches

- 5 Check that the pins are properly seated in the socket then press down firmly on the center of the chip until it is fully seated.

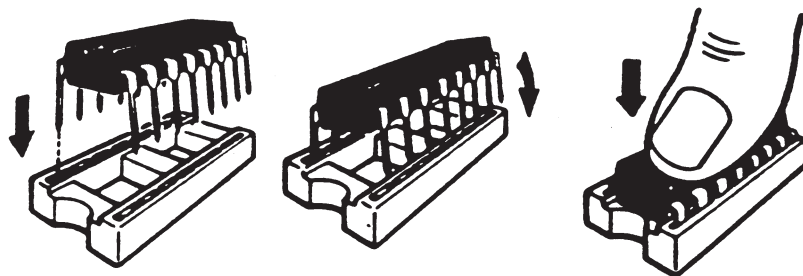

Figure 4-3. Installing the Chip

GAS CORRECTION FACTOR TABLE

Gas correction factor tables are only reproduced for the convenience of the user and do not imply that use with other gases will be safe with hot filament gauge controllers. The following table lists relative gauge gas correction factors for various gases. The values are derived by empirical methods substantiated by measurements reported in literature. This table has been compiled and published by Robert L. Summers of Lewis Research Center, NASA Technical Note TND-5285, National Aeronautics and Space Administration, Washington, DC, June 1969.

To automatically convert readings of the Multi-Gauge Controller (normally calibrated for nitrogen), enter the relative gas correction constant through the front panel key function F GAS CORR. By entering the gas constant, the gauge will divide the result by the gas correction constant and display the correct adjusted value. However, a proper understanding for the transformation of the result is required. The correction for different gas species is purely mathematical. The sensitivity of the tube is affected by different gases which, in turn, are responsible for the tube output being manipulated by the pressure equation. There will be some loss in resolution of the instrument when gas correction constants are used. The loss in resolution will become more apparent as the correction constants approach 0.5 from either direction. When the correction constants are 0.1 or 10, the tube output is 1/10 or 10 times normal. This will cause the instrument to lose the high vacuum decade or the near atmosphere decade, respectively.



NOTE

Some gases have several correction factors listed. In these cases, the top number is the most commonly-used value.

Appendix A

Gas Correction Factor Table

Substance	Formula	Relative Ionization Gauge Gas Correction Factor
Acetaldehyde	C ₂ H ₄ O	2.6
Acetone	(CH ₃) ₂ CO	3.6
		4.0
		3.6
Acetylene	C ₂ H ₂	1.9
		2.0
Air		1.0
		0.98
Ammonia	NH ₃	1.3
		1.2
		1.3
Amylene: ISO· cyclo·	ISO·C ₅ H ₁₀	5.9
	CY·C ₅ H ₁₀	5.8
Argon	Ar	1.3
		1.1
		1.2
		0.9
Benzene	C ₆ H ₆	5.9
		5.8
		5.7
		5.9
		6.0
Benzoic Acid	C ₆ H ₅ COOH	5.5
Bromine	Br	3.8
Bromomethane	CH ₃ Br	3.7
Butane: n· ISO·	n·C ₄ H ₁₀	4.9
		4.7
	ISO·C ₄ H ₁₀	4.6
		4.9
Cadmium	Cd	2.3
		3.4
Carbon Dioxide	CO ₂	1.4
		1.4
		1.5
		1.5
		1.4

Substance	Formula	Relative Ionization Gauge Gas Correction Factor
Carbon Disulfide	CS ₂	5.0
		4.7
		4.8
Carbon Monoxide	CO	1.05
		1.05
Carbon Tetrachloride	CCl ₄	1.1
		6.0
Cesium	Cs	6.3
		4.3
Chlorine	Cl ₂	2.0
		4.8
		0.68
Chlorobenzene	C ₆ H ₅ Cl	2.6
		1.6
		7.0
Chloroethane	C ₂ H ₅ Cl	4.0
Chloroform	CHCl ₃	4.7
		4.8
		4.8
		4.8
Chloromethane	CH ₃ Cl	2.6
		3.2
		3.1
Cyanogen	(CN) ₂	2.8
		3.6
		2.7
Cyclohexylene	C ₆ H ₁₂	7.9
		6.4
Deuterium	D ₂	0.35
		0.38
Dichlorodifluoromethane	CCl ₂ F ₂	2.7
		4.1
Dichloromethane	CH ₂ Cl ₂	3.7
Dinitrobenzene o· m· p·	C ₆ H ₄ (NO ₂) ₂	7.8
		7.8
		7.6
		7.6
Ethane	C ₂ H ₆	2.6
		2.8
		2.5
Ethanol	C ₂ H ₅ OH	3.6
		2.9
Ethyl Acetate	CH ₃ COOC ₂ H ₅	5.0

Appendix A

Substance	Formula	Relative Ionization Gauge Gas Correction Factor
Ethyl ether	(C ₂ H ₅) ₂ O	5.1
		5.1
Ethylene	C ₂ H ₄	2.3
		2.4
		2.2
		2.2 to 2.5
Ethylene oxide	(CH ₂) ₂ O	2.5
Helium	He	0.18
		0.15
		0.13
		0.12
Heptane	C ₇ H ₁₆	8.6
Hexadiene:	1.5-C ₅ H ₁₀	6.4
		cyco-C ₆ H ₁₀
Hexane	C ₆ H ₁₄	6.6
Hexene:	1-C ₆ H ₁₂	5.9
		cyco-C ₆ H ₁₀
Hydrogen	H ₂	0.46
		0.38
		0.41
		0.45
		0.44
Hydrogen Bromide	HBr	2.0
Hydrogen Chloride	HCl	1.5
		1.6
		2.0
		1.5
Hydrogen Cyanide	HCN	1.5
		1.6
Hydrogen Fluoride	HF	1.4
Hydrogen Iodide	HI	3.1
Hydrogen Sulfide	H ₂ S	2.2
		2.2
		2.3
		2.1
Iodine	I ₂	5.4
Iodomethane	CH ₃ I	4.2
Isoamyl Alcohol	C ₅ H ₁₁ OH	2.9
Isobutylene	C ₄ H ₈	3.6
Krypton	Kr	1.9
		1.7
		1.7
Lithium	Li	1.9
Mercury	Hg	3.6
Methane	CH ₄	1.4
		1.5
		1.6
		1.4 to 1.8
		1.5
		1.5
Methanol	CH ₃ OH	1.8
		1.9
Mehtyl Acetate	CH ₃ COOCH ₃	4.0
Mythyl ether	(CH ₃) ₂ O	3.0
		3.0

Substance	Formula	Relative Ionization Gauge Gas Correction Factor
Naphthalene	C ₁₀ H ₈	9.7
Neon	Ne	0.30
		0.31
Nitrobenzene	C ₆ H ₅ NO ₂	7.2
Nitrogen	N ₂	1.0
Nitrotoluene (o-, m-, p-)	C ₆ H ₄ CH ₃ NO ₂	8.5
Nitric Oxide	NO	1.3
		1.2
		1.0
Nitrous Oxide	N ₂ O	1.5
		1.7
		1.7
		1.3 to 2.1
Oxygen	O ₂	1.0
		1.1
		0.9
		0.9
Pentane	n-C ₅ H ₁₂	6.2
		6.0
		5.7
		6.0
		5.7
ISO-neo-	ISO-C ₅ H ₁₂ (CH ₃) ₄ C	6.0
6.0		
6.0		
Phenol	C ₆ H ₅ OH	6.2
Phosphine	PH ₃	2.6
Potassium	K	3.6
Propane	C ₃ H ₈	4.2
		3.7
		3.7 to 3.9
		3.6
Propene oxide	C ₃ H ₆ O	3.9
Propene:	n-C ₃ H ₆	3.3
		3.2 to 3.7
		3.6
cyco-	cy-C ₃ H ₆	3.6
Rubidium	Rb	4.3
Silver perchlorate	AgClO ₄	3.6
Sodium	Na	3.0
Stannic iodide	SnI ₄	6.7
Sulphur Dioxide	SO ₂	2.1
		2.3
Sulphur Hexafluoride	SF ₆	2.3
		2.8
Toluene	C ₆ H ₅ CH ₃	6.8
Trinitrobenzene	C ₆ H ₃ (NO ₂) ₃	9.0
Water	H ₂ O	1.1
		1.0
		0.8
Xenon	Xe	2.9
		2.2
		2.4
Xylene:	o-C ₆ H ₄ (CH ₃) ₂	7.8
		p-C ₆ H ₄ (CH ₃) ₂

Appendix B

UHV Board – Part No. L8321301

DESCRIPTION

The UHV control printed circuit board, when used with a Multi-Gauge unit, contains all required circuitry to operate a UHV-24 or similar ion gauge. It can be installed in any one of the five slots in the Multi-Gauge unit; however, since it is a “high-profile” board, Varian recommends that it be put into one of the three right-hand slots, as viewed from the front of the unit, for maximum flexibility. After installation, the UHV label should be placed on the area provided to help in identifying the card after the cover is installed.

SPECIFICATIONS

Electrometer Accuracy	$>10^{-10}$ Torr \pm 5 percent of ion current reading (ion current = > 10 pa) $<10^{-10}$ Torr \pm 20 percent of ion current reading (ion current = <10 pa, $I > 4$ pa)
Emission Current Range	Set to 4.00 ma as a default, currents can be set from 10 μ a to 9.99 ma through the keypad on the front panel of the Multi-Gauge unit. The emission current will remain constant as long as the pressure is $<1 \times 10^{-5}$ Torr or the emission current is set to ≤ 1.00 mA. The Multi-Gauge automatically reduces the current by a factor of 10 when the pressure is $>5 \times 10^{-5}$ Torr and the emission current is set to ≥ 1.01 ma.
Alternate Filament Selection	Automatic for a dual filament gauge; “EMIS 2” indicator light will light to indicate that the second filament is active.
Overpressure Protection	Automatic gauge tube turnoff when pressure equals or exceeds 1×10^{-3} Torr.
Degas	Electron beam bombardment, including the collector lead; 400 V at 65 ma. Can activate only if pressure is $<10^{-5}$ Torr and no other board is degassing. Automatic timeout of approximately 15 to 25 minutes depending on the Multi-Gauge card configuration.
Recorder Output	1V/decade log-linear output (two-conductor Micro Jax connector plug supplied with board). Recorder output reflects changes in sensitivity and gas correction factors.
Fault Detections	No ion current – E03; emission current or amplifier fault, check emission current setting; low grid voltage (low degas voltage when in Degas mode) – E06; open filament or no filament current – E05; filament circuit/cable short – E04; overtemperature shutdown - gauge power shuts off when internal temperature reaches $\geq 65^{\circ}\text{C}$ – E07. The error codes are listed in the Multi-Gauge basic unit manual, Section 4-3.

Cable Length

Standard cables with lengths of 10, 25, 50, 75, and 100 feet are available from stock. Longer cables are available on special order (see Table 1). Connections are made at the rear of the card as shown in Figure 1.

Table 1

Length (feet)	Wire Size (AWG) Each Wire
Up to 50	18
75	16
100	14
200	12
500	8

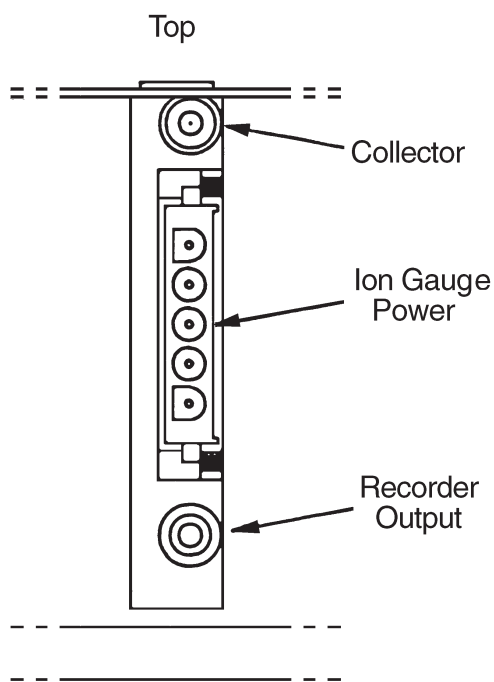

Figure 1. Card Connections

Sensitivity

Set to 25 per Torr as a default, can be set from 0.1 to 99.9 per Torr through the keypad.

Gas Correction

Set to 1.00 (N₂) as a default, can be set from 0.01 to 9.99 through the keypad. See Appendix A for the Gas Correction Factor Table.

 **NOTE**

Measurements in the ultra-high vacuum range may be inaccurate or impossible due to increased leakage currents and other effects due to long cable lengths. It is recommended that teflon low-capacitance cable be used and that it be rigidly mounted to avoid triboelectric and leakage effects.

CALIBRATION AND ADJUSTMENTS

None; the system automatically self-calibrates in use to compensate for component variations with temperature and time.

UHV Control Card Operation

Multi-Gauge will indicate the presence of a UHV control card by lighting the blue “UHV” annunciator when the channel into which the card is plugged is selected via the CHAN key.

Upon initial power up, the main display will show OFF, indicating that the gauge is not measuring pressure.

To measure pressure:

- 1 Press EMIS.
- 2 The main display will indicate “---” for several seconds along with the red EMIS.
- 3 If the emission was successfully established, the main display will indicate pressure with the red EMIS annunciator on. In addition, a red 2 will be lit if the gauge tube’s second filament is operating, an indication that the first filament is burned out.
- 4 Should an error message be displayed, refer to Section IV, Varian manual number 6999-09-091, for troubleshooting procedures.

To stop measuring pressure:



NOTE

With software revision 2.4 or later, the keypad sequence F EMIS will turn on filament 2 from the OFF state. EMIS is still used to turn off the emission.

- 1 Simply press the EMIS button. The red EMIS annunciator will go out and the main display will show OFF to indicate that the gauge filament has been shut off. (Pressing the EMIS button will also remove any error messages from the displays allowing the operator to retry emission if desired.)



NOTE

Multi-Gauge will degas only one ion gauge at a time.

To activate the DEGAS function:

- 1 The ion gauge must be on and displaying a pressure reading less than 1×10^{-5} Torr (1.33×10^{-5} mBar or 1.33×10^{-3} PASCAL) and there must not be any other board degassing.
- 2 Press the DEGAS button. If the pressure condition in step 1 is met, degassing of the gauge will begin. The main display will show "---" along with the red DEGAS annunciator. The operator should remember that the gauge cannot read pressure when in the DEGAS mode since the collector lead is also being bombarded, therefore steps should be taken to prevent inadvertent venting of the system to protect the gauge.

Note: The UHV board utilizes electronic bombardment degassing ≈ 25 watts. Grid voltage is raised to 525 VDC and emission current @ 47 mA.

- 3 Should an error message be displayed, refer to Section IV, Varian manual number 6999-09-091, for troubleshooting procedures.

To deactivate the DEGAS function:

There are three ways to turn off the degassing system.

- 1 Do nothing. After approximately fifteen minutes, the computer in the Multi-Gauge unit will automatically turn off the DEGAS function. Emission will also shut off for <500 msec, then turn back on with the display showing "---" while emission is re-established.
- 2 Press DEGAS. This will also terminate the DEGAS function, leaving the tube on to read pressure after the momentary emission shut-off and re-establishment.
- 3 Press EMIS. This will simultaneously turn off the DEGAS and gauge EMISSION functions. The display will show OFF.

Using the Recorder Output

To use the recorder output feature, assemble a cable to the Micro Jax plug supplied with the UHV control card. Varian strongly recommends using a coaxial cable to maintain compliance with FCC regulations. Refer to Figure 2 for instructions on assembling the cable.

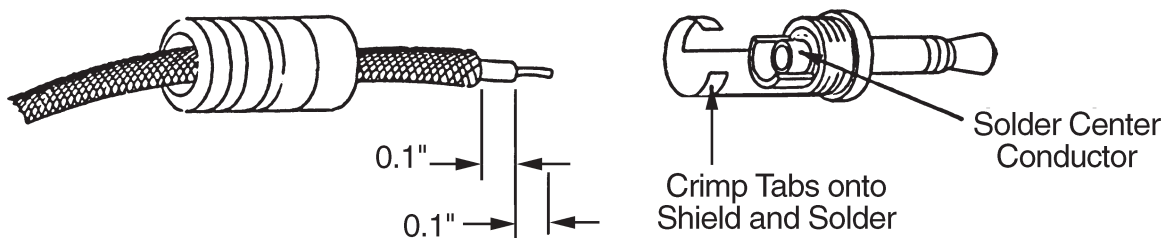

Figure 2. Assembling the Cable/Plug

Any recorder with an input impedance greater than 2,000 ohms and which has a full scale input range of +10V can be used.

The output characteristics are shown in Figure 3.

The recorder output reflects the reading on the display and does not require adjustments to compensate for different emission or sensitivity settings. When the gauge is off, the output is 10V. When degassing, the output is 0 volts.

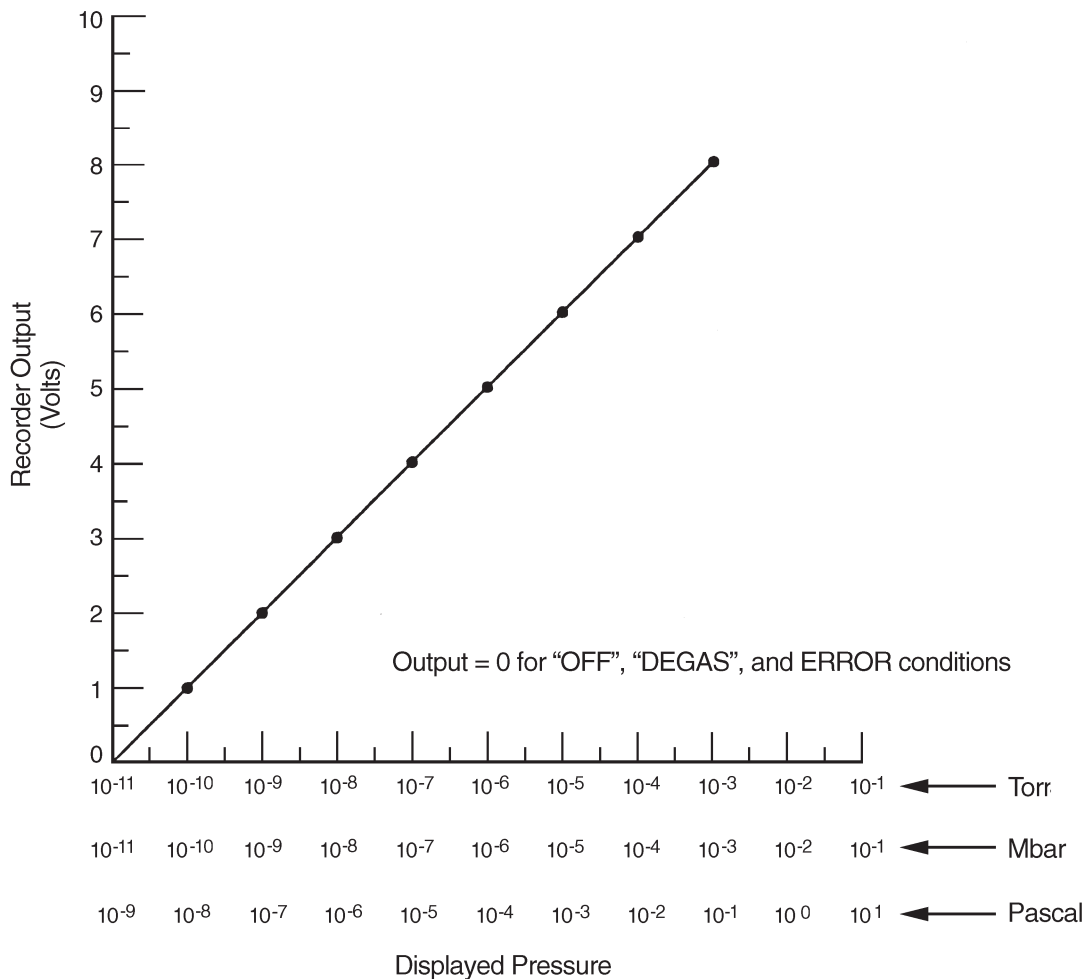

Figure 3. Recorder Output Characteristics

Algorithm: Convert recorder output voltage to pressure

To calculate the pressure from the voltage output

Example: recorder output = 4.28 volts DC

To get the exponent take the integer part of voltage output which is 4 and subtract 11:

$$4 - 11 = -7 \text{ (E-7)}$$

To find the mantissa, take the fractional portion and add .1 to it and divide by 11

$$(.28 + .1) / .11 = 3.45$$

Therefore 4.28 VDC = 3.45E-7 Torr

APPENDIX C

Thermocouple Board – Part No. L6430301

DESCRIPTION

The Thermocouple Printed Circuit Control Board, when used with a Multi-Gauge unit, contains all the circuitry required to operate four Model 531 thermocouple gauge tubes. It can be installed in any one of the five slots in the Multi-Gauge basic unit. After installation, the TC label should be placed on the area provided to help in identifying the card after the cover is installed. Up to two TC cards may be installed for a total of eight available thermocouples.

SPECIFICATIONS

Software required	Revision P1.1 or later
Pressure range	2 Torr to 1×10^{-3} Torr
TC heater current	165 ma $\pm 10\%$
TC Resistance	Approximately 1.4 ohms from pin to pin
Cable length	Standard lengths of 10, 25, 50, 75, and 100 feet are available from stock. Longer lengths (up to 500 feet) are available on special order. Connections are made to the rear of the card.
Recorder output	0 to 10V non-linear; see Figure 1 for connections of user-supplied wiring. Varian recommends the use of shielded wiring to maintain compliance with FCC regulations for radiated emissions. The recorder output does not reflect ATM or VAC settings.
Fault Detections	No cable or open TC circuit; TC power supply fault. The error codes are listed in the Multi-Gauge basic manual (part no. 6999-08-091), section 4-3.

OPERATION

Signal	Pin No.
TC1 rec out	3
TC1 rec gnd	20
TC2 rec out	10
TC2 rec gnd	24
TC3 rec out	15
TC3 rec gnd	27
TC4 rec out	6
TC4 rec gnd	31

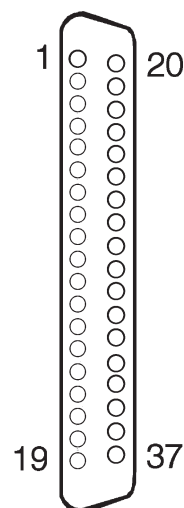

Figure 1. 37-Pin Connector

Multi-Gauge will indicate the presence of the TC card by lighting the curved bargraph display. The thermocouple being displayed is identified by the "TC" number just beneath the bargraph. The TC reading is also displayed on the main digital display when there are no blue annunciators lit. Multi-Gauge also provides the capability to select any one of the installed TCs on the bargraph simultaneously with a main ion gauge, such as a UHV or Bayard-Alpert gauge, by using the up or down arrows. This will cause the TC identifier to scroll through the installed thermocouples.

If two thermocouple cards are installed in the basic unit, Multi-Gauge will assign the identification TC1, TC2, TC3, and TC4 to the leftmost installed TC card (as viewed from the front of the unit) and TC5, TC6, TC7, and TC8 to the rightmost installed card.

THERMOCOUPLE PRINCIPLES OF OPERATION

A thermocouple operates on the principle that, at sufficiently low pressures, the thermal conductivity of the gas decreases with a decrease in pressure. A thermocouple is attached to a heater wire in which the temperature is raised to approximately 350°C by passing a current through the wire. When constant power is maintained through the heater wire, the temperature measured by the thermocouple will change with pressure. This change is directly related to the heat conducted away by the gas in the environment. The electromotive force (emf) measured from the thermocouple is read on a scale which has been calibrated for pressure.

The response of the thermocouple is also affected by factors other than pressure. Normally, the tube is calibrated for nitrogen or air. If the residual gas in the vacuum system is some other gas, the pressure reading may be affected. As an example, hydrogen and helium will conduct the heat away from the thermocouple more rapidly than air, leading to an erroneous reading which will be higher than the actual pressure. Contaminants such as oil, dust, and other chemicals can change the surface of the thermocouple and heater which, in turn, will change the ability of the thermocouple to dissipate the heat and affect the pressure reading.

Because the thermocouple gauge tube is a thermal response device, the ability of the tube to respond to abrupt pressure changes is limited by the mass of the thermocouple and heater. If this combination is very small, the tube responds more rapidly than a tube with larger wire sizes.

In general, thermocouple gauge tubes are used to gain an indication of the vacuum in a system rather than an accurate measure. So many factors can affect the output of the tube that unless special care and precautions are taken, the pressure read on the control is usually accurate to within ± 30 percent of the indicated reading.

Thermocouple gauge tubes should be positioned on the vacuum system so that contaminants do not collect in the tube. Preferably, the tube port should be oriented down to prevent oil from mechanical pumps, etc. from building up in the tube.

CALIBRATION

Before using the thermocouple card for pressure measurements, the operator must first set the atmosphere and vacuum readings by using the ATM and VAC keys.

- 1 Set the atmosphere reading by selecting the desired thermocouple using the CHAN key. Make sure that the TC is exposed to atmospheric pressure. Press the ATM key. The main display will read 760 Torr, or the equivalent in mBar or Pascal, as desired.

- 2 Set the vacuum reading by selecting the desired thermocouple using the CHAN key. Expose the selected thermocouple to a known vacuum level as high as 9.9×10^{-2} Torr or mBar (9.9×100 Pascal) or to a vacuum level lower than 10^{-3} Torr or mBar (10^{-1} Pascal). Press the VAC key. The display will show the most recent vacuum setting (initially 1.0×10^{-3} Torr) with the most significant digit flashing. Using the standard “digit setting” procedure described in the Multi-Gauge Controller manual (6999-08-091), set the display to the vacuum level desired to calibrate the thermocouple. The thermo-couple is now calibrated.



NOTE

Since the Multi-Gauge will calibrate the thermocouple to any ATM or VAC setting, the user is responsible for applying these functions accurately.

AUTO TURN-ON

Using a TC card in conjunction with an ion gauge card allows the user to program a thermocouple to automatically turn on emission for an ion gauge. The Auto-On feature allows programming of the turn-on level between 1×10^{-3} Torr and 5×10^{-3} in Torr or mBar units (1×10^{-1} to 5×10^{-1} in Pascal) for all Varian ion gauges. The Varian 564 Broad Range Bayard-Alpert gauge can also be set to turn on between 1×10^{-2} and 5×10^{-2} Torr or mbar (1×100 and 5×100 Pascal).

Programming Auto-On

- 1 Use the CHAN key to select the ion gauge desired to automatically turn on.
- 2 Press the AUTO-ON key. The red SELECT AUTO-ON annunciators will light along with the number of the first available thermocouple or the number of a previously assigned thermocouple. The main display will show a pressure setting if assigned or 0.00 mantissa if not assigned. Pressing AUTO-ON again will select the next available thermocouple or exit to the pressure display.
- 3 Once the desired thermocouple is selected, set the actual turn-on pressure by changing the flashing digit values according to the “digit setting” procedure described in the Multi-Gauge Controller manual 6999-08-091. To cancel the Auto turn-on, set the mantissa to 0.00. Once all flashing digits are set, AUTO-TURN ON programming is complete.
- 4 When the Auto Turn-On is enabled for a given ion gauge, the EMIS key can still be used to turn off the ion gauge. Turning off the ion gauge with the EMIS key will disable the Auto Turn-On setting and requires the user to enter the Auto-On programming routine to re-activate the Auto-On setting.



NOTE

Every thermocouple is available as a turn-on source, regardless of whether it has a setpoint assigned to it or whether it has been assigned to turn on another ion gauge.

RECORDER OUTPUT

Figure 2 shows a plot of nominal thermocouple response versus pressure for various common gases as available at the recorder output terminal. Since the recorder output does not reflect the results of using the ATM or VAC functions, use of these outputs should be restricted to providing an indication of changes in pressure levels as opposed to absolute measurements.

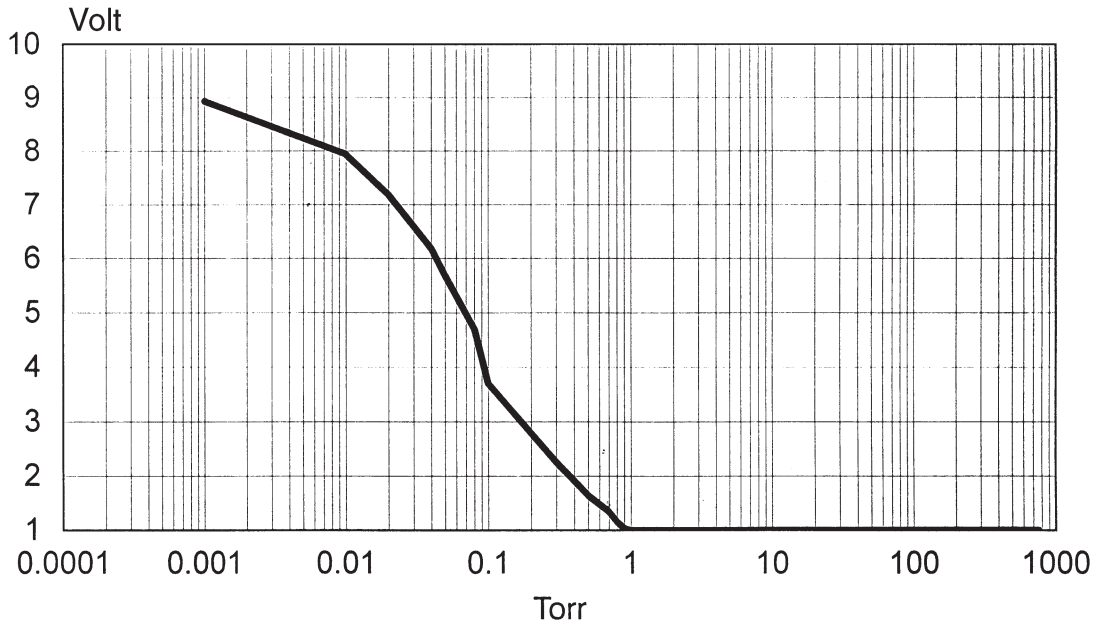

Figure 2. Response vs. Pressure Curves

APPENDIX D

Bayard-Alpert Board – Part No. L6427301

DESCRIPTION

The Bayard-Alpert (B/A) control printed circuit board, when used with a Multi-Gauge unit, contains all required circuitry to operate a 563, 564, 571, 572, 580, or similar ion gauge. It is necessary to set a jumper on the B/A board to identify the type of B/A tube being used. To operate a standard B/A tube (563, 571, or 572), position the jumper as shown in Figure 1. To operate a broad range B/A tube (564 or 580), position the jumper as shown in Figure 2. The jumper is set at the factory to the standard B/A tube position.

The B/A board can be installed in any one of the five slots in the Multi-Gauge unit; however, since it is a “high-profile” board, Varian recommends that it be installed in one of the three right-hand slots, as viewed from the front of the unit, for maximum flexibility. After installation, the B/A label should be placed on the area provided to help in identifying the card after the cover is installed.

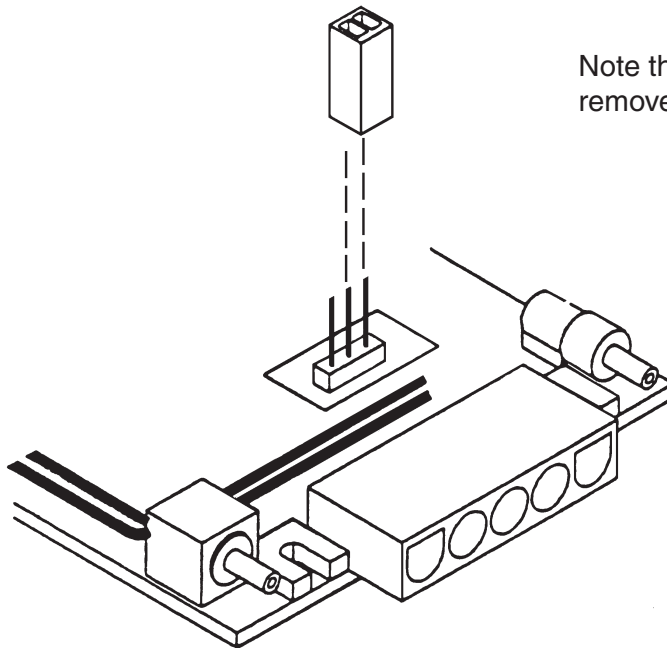

Figure 1. Jumper position, standard tube

Note that the connector plate has been removed for illustration clarity.

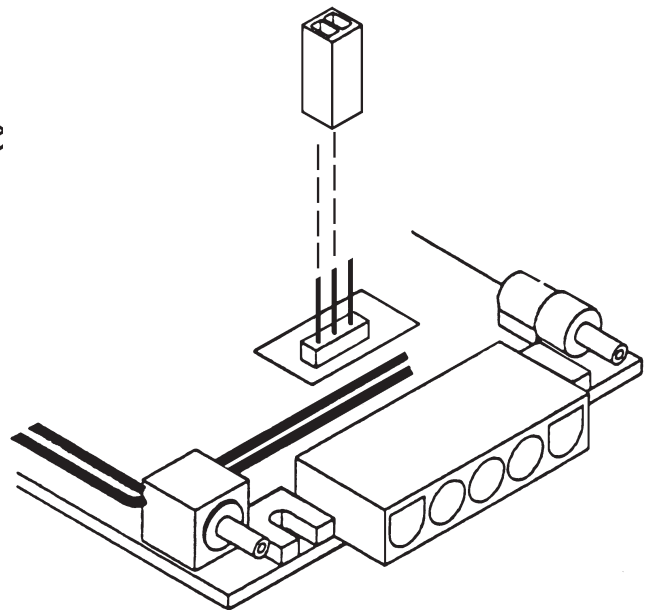

Figure 2. Jumper position, broad-range tube



NOTE

When using the Multi-Gauge BA card to operate an early model Varian 580 (or another manufacturer's) nude gauge, it may be necessary to cut the grid support pin flush with the standoff as shown in the following illustration. Failure to do so may damage the BA card. **Wear eye protection while cutting the pin.**

SPECIFICATIONS

Software Required	Revision P1.1 or later
Electrometer Accuracy	>10 ⁻¹⁰ Torr ±5 percent of ion current reading (ion current = > 10 pa) <10 ⁻¹⁰ Torr ±20 percent of ion current reading (ion current = <10 pa, I > 4 pa)
Emission Current Range	Set to 4.00 ma as a default, currents can be set from 10 µa to 9.99 ma through the keypad on the front panel of the Multi-Gauge unit. The emission current will remain constant as long as the pressure is <1 x 10 ⁻⁵ Torr or the emission current is set to ≤ 1.00 mA. The Multi-Gauge automatically reduces the current by a factor of 10 when the pressure is >5 x 10 ⁻⁵ Torr and the emission current is set to ≥1.01 ma.
Alternate Filament Selection	Automatic for a dual filament gauge; "EMIS 2" indicator light will light to indicate that the second filament is active.
Overpressure Protection	Automatic gauge tube turn-off when pressure equals or exceeds 1 x 10 ⁻³ Torr for standard B/A tubes (563, 571, and 572) or 1 x 10 ⁻¹ Torr for broad range B/A tubes (564 and 580).
Degas	Resistive, 40 watts. Can activate only if pressure is ≤ 10 ⁻⁵ Torr and no other ion gauge card is degassing. Automatic timeout of approximately three hours.
Recorder Output	1V/decade log-linear output (two-conductor Micro Jax connector plug supplied with board). Recorder output reflects changes in sensitivity and gas correction factors.
Fault Detections	No ion current – E03; Emission current or amplifier fault; check emission current setting; Low grid voltage (low degas voltage when in Degas mode) – E06; Open filament or no filament current – E05; Filament circuit/cable short – E04;

Fault Detections (*Cont'd*)

Overtemperature shutdown – gauge power shuts off when internal temperature reaches $\geq 65^{\circ}\text{C}$ – E07.

The error codes are listed in the Varian Multi-Gauge basic unit manual 6999-08-091, Section 4-3.

Note: Varian offers reference ionization B/A gauges, which are sealed off at approximately $5\text{E-}6$ Torr. These gauges are extremely helpful in troubleshooting a vacuum system problem by isolating the defective component. It is important to know that these reference ion gauge tubes are not NIST traceable calibrated gauges but act only as a load for the ion gauge controller.

Contact Varian's Customer Service for more info @ 1-800-8-VARIAN

Cable Length

Standard cables with lengths of 10, 25, 50, 75, and 100 feet are available from stock. Non-standard length cables (up to 500 feet) are available on special order (see Table 1). Connections are made at the rear of the card as shown in Figure 3.

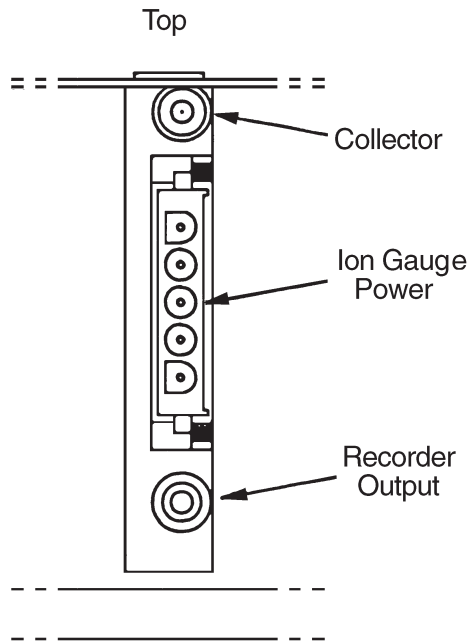

Figure 3. Card Connections

Table 1

Length (feet)	Wire size (AWG) each wire
Up to 50	18
75	16
100	14
200	12
500	8



NOTE

Measurements in the high vacuum range may be inaccurate or impossible due to increased leakage currents and other effects due to long cable lengths. It is recommended that teflon low-capacitance cable be used and that it be rigidly mounted to avoid triboelectric and leakage effects.

Sensitivity	The default setting is 10.0 per Torr for standard B/A tubes (563, 571, and 572) and 8.0 per Torr for broad range B/A tubes (564 and 580). Can be set from 0.1 to 99.9 per Torr through the keypad.
Gas Correction	Set to 1.00 (N ₂) as a default, can be set from 0.01 to 9.99 through the keypad. See Appendix A for the Gas Correction Factor Table.

CALIBRATION AND ADJUSTMENTS

None; the system automatically self-calibrates in use to compensate for component variations with temperature and time.

B/A Control Card Operation

Multi-Gauge will indicate the presence of a B/A control card by lighting the blue “B/A” annunciator when the channel into which the card is plugged is selected via the CHAN key.

Upon initial power up, the main display will show OFF, indicating that the gauge is not measuring pressure.

To measure pressure:

- 1 Press EMIS.
- 2 The main display will indicate “---” for several seconds along with the red EMIS.
- 3 If the emission was successfully established, the main display will indicate pressure with the red EMIS annunciator on. In addition, a red 2 will be lit if the gauge tube’s second filament is operating, an indication that the first filament is burned out.
- 4 Should an error message be displayed, refer to Section IV of the basic manual for troubleshooting procedures.



NOTE

With software revision 2.4 or later, the keypad sequence F EMIS will turn on filament 2 from the OFF state. EMIS is still used to run off the emission.

- 5 At pressures higher than 1 mTorr, performance is greatly improved by lowering the emission current to 0.1 mA or lower. (Refer to Section 3.3, item 7, in the Multi-Gauge Controller manual.) this prevents the gauge from giving false readings.



NOTE

This will raise the lowest pressure able to be read to 1×10^{-8} Torr, even higher is set lower. Again, performance is improved as the emission current is lowered.

To stop measuring pressure:

- 1 Simply press the EMIS button. The red EMIS annunciator will go out and the main display will show OFF to indicate that the gauge filament has been shut off. (Pressing the EMIS button will also remove any error messages from the displays allowing the operator to retry emission if desired.)

To activate the DEGAS function:



NOTE

Multi-Gauge will degas only one ion gauge at a time.

- 1 The ion gauge must be on and displaying a pressure reading less than 1×10^{-5} Torr (1.33×10^{-5} mBar or 1.33×10^{-3} PASCAL).
- 2 Press the DEGAS button. If the pressure condition in step 1 is met, degassing of the gauge will begin. The main display will show a pressure reading along with the red DEGAS annunciator.
- 3 Should an error message be displayed, refer to Section IV for troubleshooting procedures.

To deactivate the DEGAS function:

There are three ways to turn off the degassing system.

- 1 Do nothing. After approximately three hours, the computer in the Multi-Gauge unit will automatically turn off the DEGAS function. Emission will also shut off for <500 msec, then turn back on with the display showing “---” while emission is re-established.
- 2 Press the DEGAS button. If the pressure condition in step 1 is met, degassing of the gauge will begin. The main display will show a pressure reading along with the red DEGAS annunciator.
- 3 Press EMIS. This will simultaneously turn off the DEGAS and gauge EMISSION functions. The display will show OFF.

Using the Recorder Output

To use the recorder output feature, assemble a cable to the Micro Jax plug supplied with the B/A control card. Varian strongly recommends using a coaxial cable to maintain compliance with FCC regulations. Refer to Figure 4 for instructions on assembling the cable.

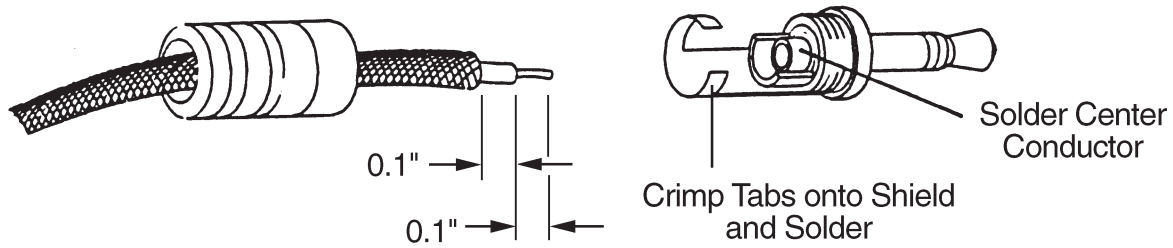

Figure 4. Assembling the Cable/Plug

Any recorder with an input impedance greater than 2,000 ohms and which has a full scale input range of +10V can be used.

The output characteristics are shown in Figure 5.

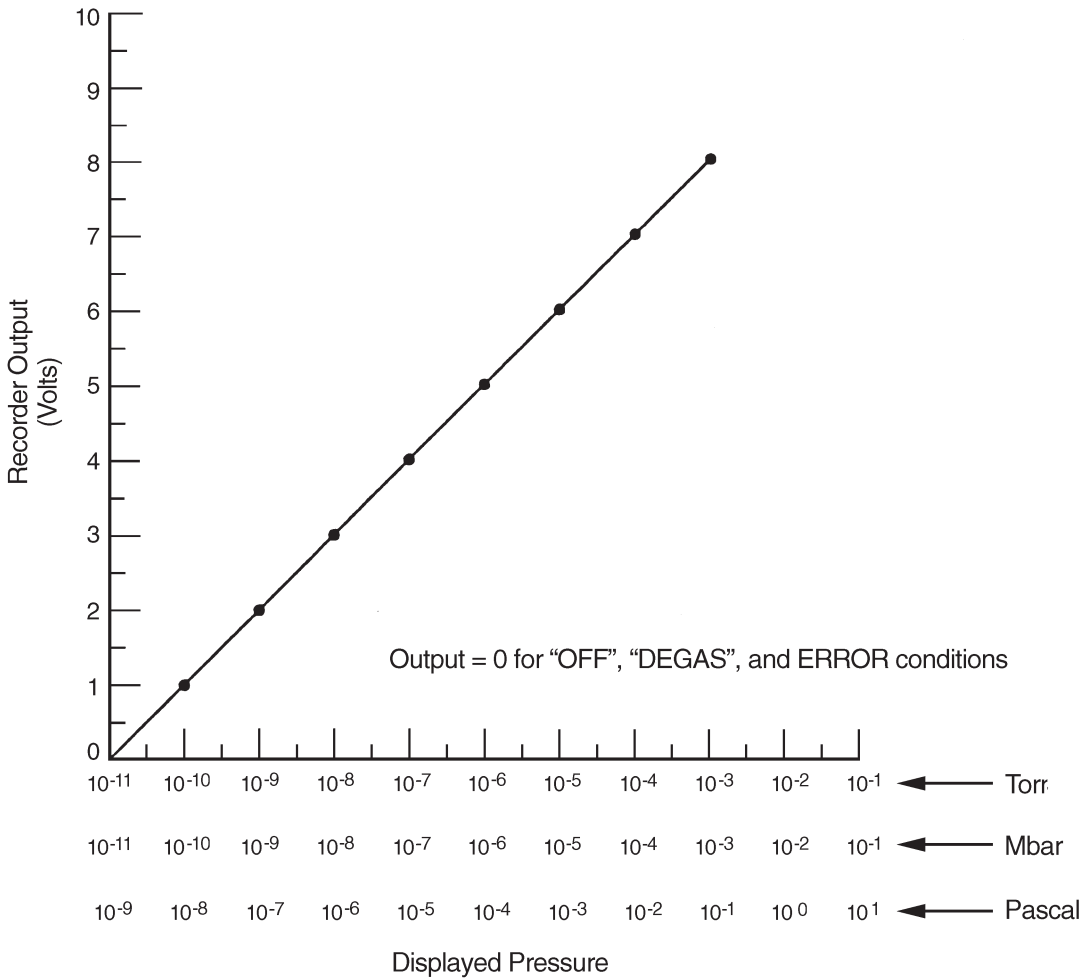

Figure 5. Recorder Output Characteristics

Appendix D

Algorithm: Convert recorder output voltage to pressure

To calculate the pressure from the voltage output

Example: recorder output = 4.28 volts DC

To get the exponent take the integer part of voltage output which is 4 and subtract 11:

$$4 - 11 = -7 \text{ (E-7)}$$

To find the mantissa, take the fractional portion and add .1 to it and divide by 11

$$(.28 + .1)/.11 = 3.45$$

Therefore 4.28 VDC = 3.45E-7 Torr

The recorder output reflects the reading on the display and does not require adjustments to compensate for different emission or sensitivity settings. When the gauge is off, the output is 0 volts.

APPENDIX E

Cold Cathode Board – Part No. L6433301

DESCRIPTION

The Multi-Gauge Cold Cathode Board is designed to operate the Varian 524 (bakeable) and 525 (non-bakeable) gauge heads with cable lengths of up to 500 feet. Its operating voltage is –2 KV and its nominal sensitivity is 5 amperes/Torr. The use of software linearization and dynamic power modulation allows a useful range exceeding 1×10^{-2} to 1×10^{-7} Torr.



CAUTION

Cold Cathode Gauges require the use of a **High-Voltage** source which can be **lethal**. Proper grounding of the Multi-Gauge unit and the gauge head are necessary. **Use extreme caution** when working with these instruments; the instrument must be operated only by properly trained personnel. **Do not operate the multi-gauge with the cover off.**

The Cold Cathode board can be installed in any one of the five slots in the Multi-Gauge unit; however, since it is a “high-profile” board, Varian recommends that it be put into one of the three right-hand slots, as viewed from the front of the unit, for maximum flexibility. After installation, the [CC] label should be placed on the area provided at the rear of the unit to help in identifying the card after the cover is installed.

SPECIFICATIONS

Software Required	Revision P1.7 or later.
Electrometer Accuracy	$>10^{-6}$ Torr ± 5 percent of ion current reading (ion current = $> 5 \mu\text{A}$)
Overpressure Protection	Automatic gauge tube turn-off when pressure equals or exceeds 2×10^{-2} Torr.
Recorder Output	1V/decade log-linear output (two-conductor Micro Jax connector plug supplied with board). Recorder output reflects changes in sensitivity and gas correction factors.
Fault Detections	No ion current; power supply error; overcurrent/cable short; overtemperature shutdown – gauge power shuts off when internal temperature reaches $\geq 65^\circ\text{C}$. The error codes are listed in the Multi-Gauge basic unit manual, Section 4-3.
Cable Length	Standard cables with lengths of 10, 25, 50, 75, and 100 feet are available from stock. Longer cables (up to 500 feet long) are available on special order. Connections are made at the rear of the card as shown in Figure 1.

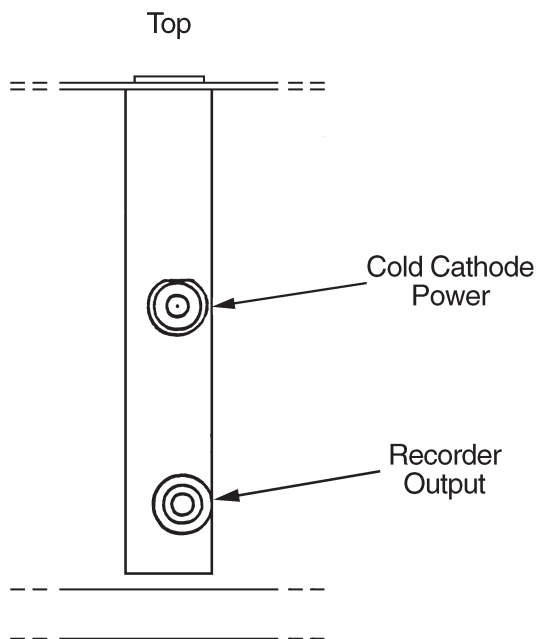



Figure 1. Card Connections

Sensitivity	Set to 5 amperes per Torr as a default, can be set from 0.1 to 99.9 amperes per Torr through the keypad second function F SENS.
Gas Correction	Set to 1.00 (N ₂) as a default, can be set from 0.01 to 9.99 through the keypad second function F GAS CORR. See Appendix A for the Gas Correction Factor Table.

 **NOTE**

Measurements in the high vacuum range may be inaccurate or impossible due to increased leakage currents and other effects due to long cable lengths. It is recommended that teflon low-capacitance cable be used and that it be rigidly mounted to avoid triboelectric and leakage effects.

THEORY OF OPERATION

The cold cathode gauge represents one of the most popular methods of high vacuum measurement through the use of ionization. Its simplicity, durability, and relatively low cost make this gauge an attractive choice for many high-vacuum gauging requirements. However, one should be aware of the operational characteristics and limitations of the cold cathode gauge before using it in a system.

The gauge consists of a controller to provide the high voltage as well as a readout for the pressure, and a sensor that is connected to the system where pressure is to be monitored. The sensor can be of several types, a simple Penning type or a more complex magnetron structure. The latter type (Redhead magnetron type) will be used as an illustration in this discussion.

An ionization chamber containing a cylindrical cathode with end caps is surrounded by a conducting metal wall. A high-voltage supply is connected in series with a meter and the ionization chamber. A magnetic field of about 1000 gauss is introduced with flux lines parallel to the axis of the cathode. Figure 2 illustrates the cross-section of the cold cathode gauge tube.

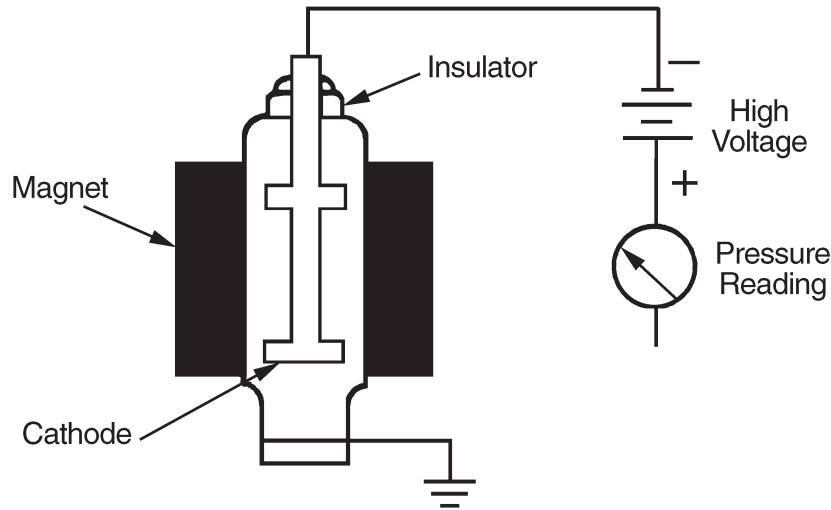

Figure 2. Cross-Section Drawing of Cold Cathode Gauge

When this tube is subjected to a total pressure below approximately 10^{-1} Torr, an electron is removed from the cathode by the strong electrostatic field and finds itself in an orbit around the cathode perpendicular to the magnetic field. The electron will then collide with gas molecules present, thus ionizing them, producing positively charged ions and free electrons. The resulting free electrons also travel in orbits about the cathode and ionize other gas molecules present. This “avalanche effect”, once started, takes milliseconds to arrive at a final value (dependent upon pressure). The positive ions are collected by the cathode and the resultant current is proportional to the pressure. To determine the ion current at a given pressure, the sensitivity of the tube must be known. This is determined by the particular geometry of the tube. The 524 and 525 gauges have a sensitivity of approximately 5 amperes/Torr. This means at 1×10^{-1} Torr, the ion current will be 500 mA. At the usual 2 KV supply voltage, this results in a power dissipation of 1000 watts within the tube! This, obviously, is not done and, in conventional controls, current limiting must be used so that the maximum current is approximately 1 mA, resulting in an upper pressure reading capability typically in the 10^{-3} Torr range.

With a Multi-Gauge Cold Cathode control board, pressure can be read from 1×10^{-2} Torr to 1×10^{-8} Torr. This is accomplished by supplying a pulsating DC current to the tube. In operation, a cold cathode gauge requires a minimum DC voltage to “fire”. This threshold voltage is dependent upon pressure and reduces in value as the pressure rises.

GAUGE TUBE POSITIONING

The cold cathode gauge tube will operate in any orientation. The user must keep in mind that there is a strong magnetic field around the tube; therefore, when near other magnetic material, the tube must be handled with great care.

Gauge tube positioning on a vacuum system is very important if dependable readings are to be obtained. The tube port should be located as close to the desired region of measurement as possible. If the port is near or facing cryogenic surfaces, the apparent pressure reading will be significantly lower than actual pressure. Locations near the inlets to high-vacuum pumps should be avoided. Since the gas discharge in the tube will break down hydrocarbons causing contamination of the gauge tube, the tube should be protected from direct exposure to mechanical and diffusion pump fluids.

If further discussion on the theory and operation of cold cathode gauge vacuum measurement is desired, the following references should be used.

References

- 1 Dushman, S., Lafferty, J.M., SCIENTIFIC FOUNDATIONS OF VACUUM TECHNIQUE, John Wiley and Sons, Inc., Second Edition, New York, 1962
- 2 Guthrie, A., VACUUM TECHNOLOGY, John Wiley & Sons, Inc., 1963
- 3 Lewin, G., VACUUM SCIENCE AND TECHNOLOGY, McGraw-Hill, New York, 1965
- 4 Redhead, P.A. et al, ULTRAHIGH VACUUM, Chapman and Hall, London, 1968.

CALIBRATION AND ADJUSTMENTS

None; the system automatically self-calibrates in use to compensate for component variations with temperature and time.

COLD CATHODE BOARD OPERATION

Multi-Gauge will indicate the presence of a Cold Cathode card by lighting the blue [CC] annunciator when the channel into which the card is plugged is selected via the CHAN key.

Upon initial power up, the main display will show OFF, indicating that the gauge is not measuring pressure.

To measure pressure:

When the cable and gauge head are properly connected and the [CC] annunciator is lit, pressing EMIS will toggle the high voltage source and as soon as a valid pressure measurement is available, it will be displayed.

If the current measurement is zero, the Multi-Gauge will assume first that the pressure is near the under pressure limit and that there is difficulty in starting the gauge. Hyphens [- - -] will be displayed for approximately 30 seconds while attempting to fire the gauge. If no gauge current is sensed after that time, the display will show an error code of E13 (insufficient signal) and shut off. This might also indicate an open cable.

If the pressure drops below 1×10^{-8} Torr after the initial start-up period, the gauge will shut off with an error code of E12 (under pressure). Any setpoints assigned to that cold cathode will de-energize and the fault must be cleared before the cold cathode can be re-started.

If the ion current is excessively high, either E09 (over pressure) or E04 (over current) may be displayed, a possible indication of a shorted cable or excessive gauge contamination.

Other possible error codes are E07 (over temperature) and E11 (power supply error).

To stop measuring pressure:

Simply press the EMIS button. The red EMIS annunciator will go out and the main display will show OFF to indicate that the gauge has been shut off. (Pressing the EMIS button will also remove any error messages from the display allowing the operator to retry emission if desired.)

RECORDER OUTPUT

To use the recorder output feature, assemble a cable to the Micro Jax plug supplied with the Cold Cathode Board. Varian strongly recommends using a coaxial cable to maintain compliance with FCC regulations. Refer to Figure 3 for instructions on assembling the cable.

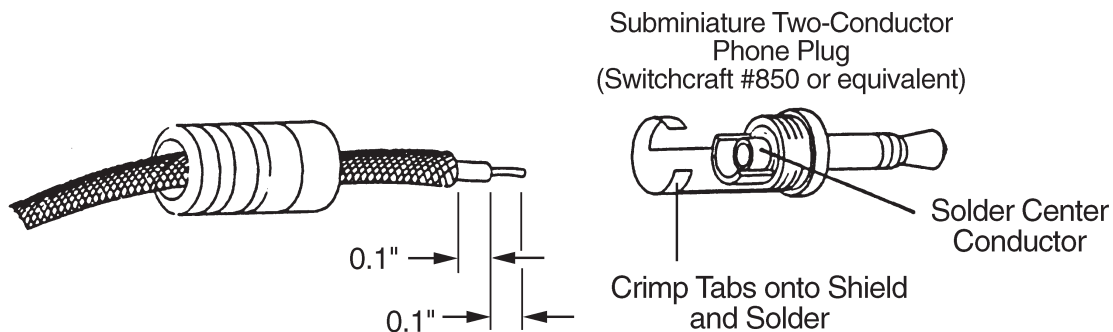

Figure 3. Assembling the Recorder Output Cable/Plug

Any recorder with an input impedance greater than 2,000 ohms and which has a full scale input range of +10V can be used.

Figure 4 shows the 1 volt/decade recorder output characteristics.

The recorder output reflects the reading on the display and does not require adjustments to compensate for different sensitivity settings. When the gauge is off, the output is 0 volts.

See page B-5 for algorithm for voltage to pressure conversion

OPERATION AT HIGH PRESSURE

If the gauge is left on for a few hours in the pressure range of 10^{-3} to 10^{-2} Torr, cathode sputtering may require frequent recalibration and maintenance. This problem is not severe for short periods of operation.

Rapid venting of the tube to atmosphere will not cause damage to the tube or gauge control. The gauge tube discharge will extinguish at a pressure of 2×10^{-2} Torr. Exposure of the gauge tube to atmospheric pressure with the control on will not be harmful to the tube.

STARTING AT LOW PRESSURE

When the gauge has been off for a period of time with the system pressure of 10^{-7} Torr or lower, delayed starting may occur. This "no-strike" condition is caused by the lower probability (at the lower pressure) of ionizing enough atoms and/or molecules to obtain the starting glow discharge condition. The indications for this are an off-scale [- - -] reading on the display. This need not be a problem in systems which are periodically cycled to air, since the gauge can be turned on in the higher pressure

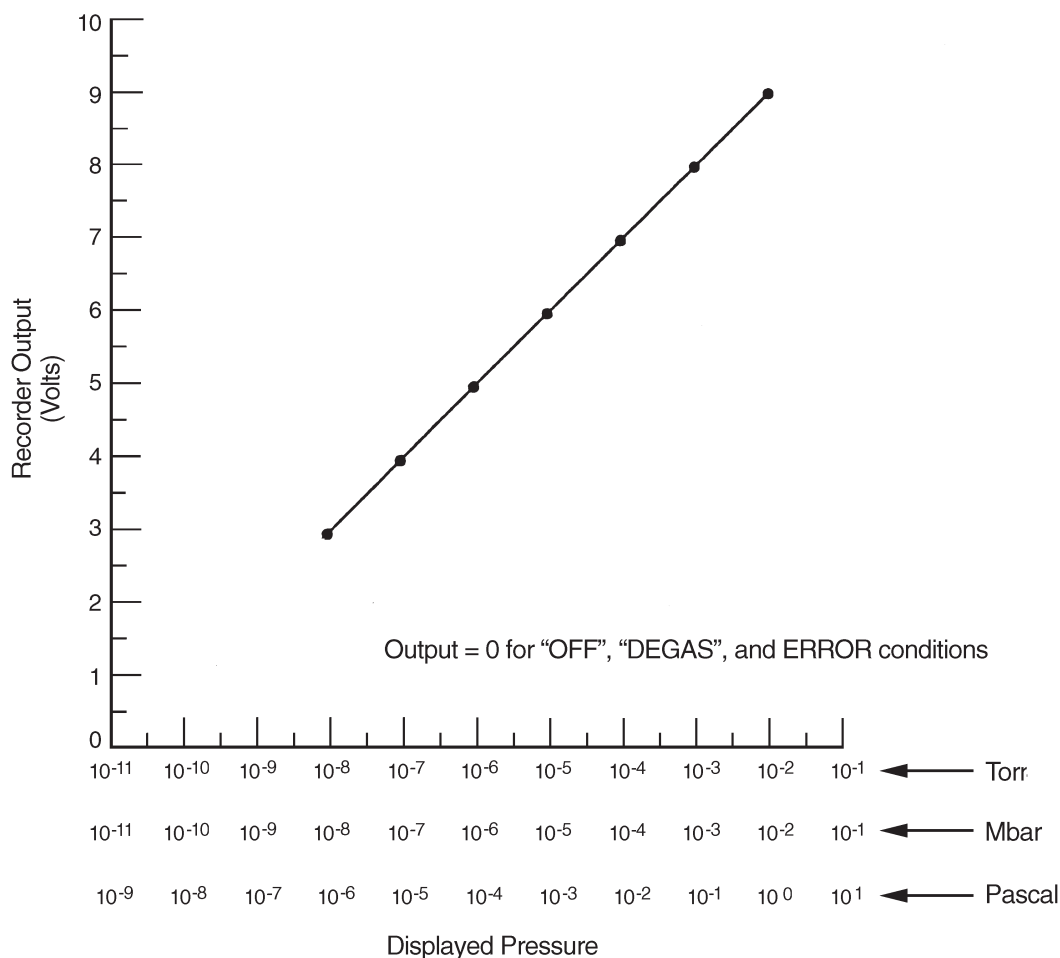

Figure 4. Recorder Output Characteristics

portion of the cycle. Once started, the gauge will not extinguish at any pressure within its operating range. If a "no-strike" condition persists for more than a few minutes, the gauge can be started by increasing the pressure in the system.

GAUGE TUBE MAINTENANCE

The gauge tube requires periodic maintenance. Leaving the gauge unoperated for sustained periods of time or exposing it to system contaminants (pump oil, for example) can be a source of trouble. These conditions will cause gases to be absorbed into the metal surfaces of the gauge tube, thus causing faulty readings and slow starting. Also, a buildup of contaminants will cause faulty or erratic readings.

One method of "cleaning up" the gauge tube is to apply heat to the gauge. This process drives the absorbed gases off the walls and surfaces of the gauge. Care should be exercised not to overheat the O-ring seals in the 525 gauge tube (maximum temperature 100°C or 212°F). The 524 tube is bakeable to 400°C (752°F) assuming the connection to the vacuum system is also bakeable.

For best results and for removing built-up contaminants, a thorough cleaning of the gauge tube is necessary. Both the anode and the cathode surfaces must be cleaned. This can be accomplished by disassembling the gauge and cleaning each part. A wire brush, steel wool, or emery cloth are good

Appendix E

surface cleaners. After brushing, the parts must be washed in soap and water (preferably Alconox), rinsed in plain water, a final rinse in alcohol, then hot-air dried if possible.

Replacement of the glass sleeve in the 524 tube may be necessary. If it appears brownish-black in color, it is heavily contaminated and must be replaced for proper operation. If a spare sleeve is not available, the old one can be used by installing it with the “clean ” end facing the threaded portion of the anode.

Description	Part No.
524 Cold Cathode Gauge Maintenance Kit	F4381301
525 Cold Cathode Gauge Maintenance Kit	F4381301

TROUBLESHOOTING

<i>Fault</i>	<i>Possible Cause/Remedy</i>
Gauge control does not read above 1×10^{-8} Torr	Check high voltage cable connection at tube and rear of control.
Gauge control reads E09 (over pressure) even when pressure is below 1×10^{-2} Torr	Check high voltage cable for a short to the center conductor. Inspect gauge tube for a low resistance from cathode to body. Insulator may be damaged.
Gauge tube won't strike a discharge	Check the green LED mounted on the top side of the cold cathode board (visible without removing the basic unit cover). If it is lit, the high voltage power supply is working. Check high voltage cable for continuity. The system pressure may be too low (E13) for the gauge tube to strike. E03 – pressure too low, check cable
Reading on gauge control is erratic	Gauge tube is contaminated. Follow procedure for disassembly and cleaning of tube.

Troubleshooting Tip

To aid in troubleshooting and to verify the integrity of the ion gauge controller or the cold cathode gauge itself, one can use a resistive dummy load. Obtain a 5.6 Meg ohm, 2 watt resistor. This value will simulate a pressure reading in the mid E-5 Torr region; higher resistor values than this will yield a lower pressure reading and lower resistor values will yield a higher pressure reading.

WARNING

When connecting the resistive load to the back of the cold cathode gauge controller, –2000 volts DC will be present. Make sure the power is off to the unit. Keep all conductive type of material away from the back of the controller when troubleshooting.

The Customer is responsible for taking the necessary safety precautions to avoid electrical shock when performing this test.

APPENDIX F

Remote I/O Board – Part No. L8324301

DESCRIPTION

The Remote I/O board interfaces easily with the Multi-Gauge basic unit; it plugs into any one of the five positions in the mother board through low- and high-voltage pin and socket connectors. The Remote I/O board allows remote operation of the Multi-Gauge without the use of an external computer. Optically-isolated inputs allow control of emission and degas functions for up to three ion gauges, and for keypad lockout. Relay contacts, also isolated, provide status outputs. External connections are made through the 37-pin, D-subminiature connector at the end of the card. See Figure 1 and Tables 1 and 2.

SPECIFICATIONS

Electrical

- Inputs optically isolated and floating; level sensitive
 3 to 32 VDC, 500 ohms minimum to activate function
 current flows in the conventional manner (into the + terminal and out of the – terminal)
- Outputs Relay contact, normally-open, gold-plated
 1/2 ampere at 24 VDC/120 VAC

Functional

 **NOTE**

When powering up the Multi-Gauge, the eight output relays will be momentarily activated for less than 100 msec before returning to the de-energized state.

Inputs (See Table 1)

1. Keypad Lockout

Applying a voltage to the + and – terminals (see Table 1) locks out the keypad except the CHAN key, and transfers control to the Remote I/O board. This input must be held active to continue control from the board. Once deactivated, all active functions will be turned off.

Note: System parameters (SETPTS, EMIS MA, etc.) can only be programmed with this input not active.

2. EMIS 1, 2, and 3

Activating these inputs will turn on emission for the first, second, and third ion gauge controllers (respectively) from the left, looking at the front of the Multi-Gauge unit. Conversely, deactivating these inputs will turn off emission.

3. DEGAS 1, 2, and 3

Activating these inputs turns on the degas function, if present, for the first, second, and third ion gauge controllers (respectively) from the left, looking at the front of the Multi-Gauge unit. Note that degas cannot be active unless the emission is active. Deactivating these inputs will turn off degas.

Table 1. Input Function vs Pin Number

Input Function	Pin Number	
	+	-
Keypad Lockout	9	10
EMIS 1	15	16
DEGAS 1	17	18
EMIS 2	7	8
DEGAS 2	19	37
EMIS 3	13	14
DEGAS 3	11	12

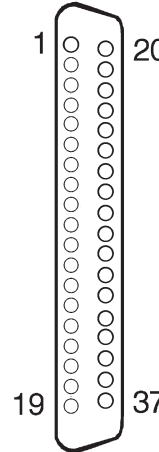

Figure 1. 37 Pin Connector

Outputs (See Table 2)

1. System Status

Contact closure to indicate no system faults.

2. EMIS 1, 2, and 3 Status

Contacts close to indicate that emission is on for ion gauge 1, 2, or 3 (respectively). Contacts open to indicate that emission is off.

3. DEGAS 1, 2, and 3 Status

Contacts close to indicate that the degas function, if any, for ion gauge 1, 2, or 3 (respectively) is on. Contacts open to indicate that degas is off.

Table 2. Output Function vs Pin Number

Output Function	Pin Number	
	+	-
System Status	4	3
EMIS 1 Status	30	31
DEGAS 1 Status	28	29
EMIS 2 Status	26	27
DEGAS 2 Status	24	25
EMIS 3 Status	22	23
DEGAS 3 Status	20	21



WARNING

Any external wiring must conform to all applicable building and electrical codes to reduce the risk of shock and fire hazards.



CAUTION

The contacts are gold-flashed making them suitable for logic level switching; however, application of AC or DC voltages greater than 20V or 20VA will cause erosion of the gold, even in just one switching cycle.



NOTE

Varian cannot guarantee compliance with FCC regulations for radiated emissions unless all external wiring is shielded, with the shield being terminated to the metal shroud on the D-sub connector. The cable should be secured to the connector with screws.

APPENDIX G

Set Point Board – Part No. L8327301 (Female Connector)

(see pg. G-3 for P/N L8727302, male pins)

DESCRIPTION

The setpoint board interfaces easily with the Multi-Gauge basic unit; it plugs into any one of the five positions in the mother board through a low voltage connector. It contains eight setpoint relays which are programmed through the Multi-Gauge unit. External connections are made through the 25-pin D-subminiature female connector at the edge of the board.

The required mating connector is a 25-pin D-subminiature plug with metal shell and solder pins. One acceptable connector, available through local distributors, is Amphenol No. 747912-2. It should be used in conjunction with Amphenol No. 205718 (cable clamp) and Amphenol No. 205980-4 (screw retainer kit). See Figure 1 and Table 1 for connection and pin information.

After installation, the SETPT label should be placed on the area provided at the rear of the unit to help in identifying the card after the cover is installed.

Any setpoint can be assigned to any one of the installed gauges (channels). The operator can program the setpoint trigger level and a hysteresis level. Hysteresis can be programmed to any level greater than or equal to the trigger level; however, it will default to 10 percent above the setpoint level if not programmed.

SPECIFICATIONS

Setpoints 8, floating SPDT relays with NO, NC, and C terminals available
 Contact Rating 3 amperes at 24 VDC/250 VAC, gold-flashed

Table 1 Setpoints vs Terminal Connections

Setpoint Number	Pin Numbers		
	C	NC	NO
1	1	2	14
2	3	15	16
3	4	17	5
4	6	18	19
5	7	9	20
6	8	21	22
7	10	11	23
8	13	24	25

*Figure 1. Female Connector Front View
 Setpoints vs Terminal Connections*

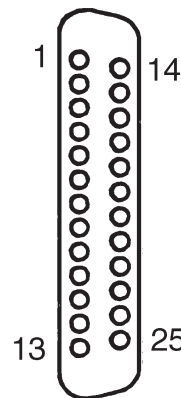

 NOTE

When powering up the Multi-Gauge, the eight setpoint relays will be momentarily activated for less than 100 msec before returning to the de-energized state.

OPERATING PROCEDURES

Programming Setpoints

Press the CHAN key to select the channel to which you wish to assign setpoints. When the channel is displayed, press the SETPT key; SELECT SETPT will appear on the display along with one or more of the numbers 1 through 8. The leftmost available setpoint or previously assigned setpoint will blink on the display to act as a display cursor. (Any numbers that show to the right of the cursor will have been assigned previously.) The number in the main display is the setpoint trigger level. Should the mantissa be 0.00, then that setpoint has not been assigned and may be, if desired. Entering a valid level, using the standard digit setting procedure, will cause that setpoint to be assigned to the displayed channel. Pressing the (hysteresis) key will display the hysteresis pressure level. The default value is +10 percent of any newly-entered trigger level but may be changed to any pressure level equal to or greater than the trigger level.

 **NOTE**

The resolution and performance of the gauge to which the setpoint is referenced should be considered when selecting both the setpoint level and the hysteresis value. See the table below:

These are suggested values only.

Gauge	Min Setpt	Max Setpt	Min Hysteresis
Thermocouple or ConvecTorr	5 mT	700 T	50% or 5 mT, whichever is greater
Capacitance Diaphragm Gauge	0.1% of full scale	100% of full scale	10% or lower
Ion Gauges	–	–	20%

If no keys are pressed while the cursor is blinking, the display will revert back to reading pressure. Should SETPT be pressed, it will advance it to the next available or previously assigned setpoint. Setpoints are programmed as outlined in para. 1.

To de-assign a setpoint (in order to change channel assignments, for example), simply set the mantissa to 0.00. It is now available for use in some other channel, if desired.

In operation, the setpoint relay will not be energized until the pressure is below the setpoint trigger level. At this point, the normally-open contacts will close and the number of the active setpoint will appear on the display, even if it is not assigned to the channel being displayed. The setpoint relay will remain energized until the pressure is greater than the hysteresis pressure level. At this point, the normally-open contacts will open and the setpoint number on the display will be turned off.

Set Point Board – Part No. L8727302 (Male Connector)

(see pg. G-1 for P/N L8327301, female pins)

DESCRIPTION

The setpoint board interfaces easily with the Multi-Gauge basic unit; it plugs into any one of the five positions in the mother board through a low voltage connector. It contains eight setpoint relays which are programmed through the Multi-Gauge unit. External connections are made through the 25-pin D-subminiature male connector at the edge of the board.

The required mating connector is a 25-pin D-subminiature plug with metal shell and solder pins. One acceptable connector, available through local distributors, is Amphenol No. 747912-2. It should be used in conjunction with Amphenol No. 205718 (cable clamp) and Amphenol No. 205980-4 (screw retainer kit). See Figure 1 and Table 1 for connection and pin information.

After installation, the SETPT label should be placed on the area provided at the rear of the unit to help in identifying the card after the cover is installed.

Any setpoint can be assigned to any one of the installed gauges (channels). The operator can program the setpoint trigger level and a hysteresis level. Hysteresis can be programmed to any level greater than or equal to the trigger level; however, it will default to 10 percent above the setpoint level if not programmed.

SPECIFICATIONS

Setpoints 8, floating SPDT relays with NO, NC, and C terminals available
 Contact Rating 3 amperes at 24 VDC/250 VAC, gold-flashed

Table 1 Setpoints vs Terminal Connections

Setpoint Number	Pin Numbers		
	C	NC	NO
1	13	12	25
2	11	24	23
3	10	22	9
4	8	21	20
5	7	5	19
6	6	18	17
7	4	3	16
8	1	15	14

Figure 2. Male Connector Front View Setpoints vs Terminal Connections

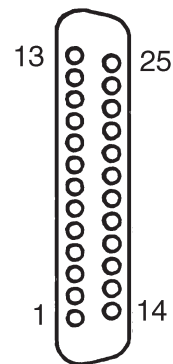

NOTE

When powering up the Multi-Gauge, the eight setpoint relays will be momentarily activated for less than 100 msec before returning to the de-energized state.

OPERATING PROCEDURES
Programming Setpoints

Press the CHAN key to select the channel to which you wish to assign setpoints. When the channel is displayed, press the SETPT key; SELECT SETPT will appear on the display along with one or more of the numbers 1 through 8. The leftmost available setpoint or previously assigned setpoint will blink on the display to act as a display cursor. (Any numbers that show to the right of the cursor will have been assigned previously.) The number in the main display is the setpoint trigger level. Should the mantissa be 0.00, then that setpoint has not been assigned and may be, if desired. Entering a valid level, using the standard digit setting procedure, will cause that setpoint to be assigned to the displayed channel. Pressing the (hysteresis) key will display the hysteresis pressure level. The default value is +10 percent of any newly-entered trigger level but may be changed to any pressure level equal to or greater than the trigger level.

 **NOTE**

The resolution and performance of the gauge to which the setpoint is referenced should be considered when selecting both the setpoint level and the hysteresis value. See the table below:

These are suggested values only.

Gauge	Min Setpt	Max Setpt	Min Hysteresis
Thermocouple or ConvecTorr	5 mT	700 T	50% or 5 mT, whichever is greater
Capacitance Diaphragm Gauge	0.1% of full scale	100% of full scale	10% or lower
Ion Gauges	–	–	20%

If no keys are pressed while the cursor is blinking, the display will revert back to reading pressure. Should SETPT be pressed, it will advance it to the next available or previously assigned setpoint. Setpoints are programmed as outlined in para. 1.

To de-assign a setpoint (in order to change channel assignments, for example), simply set the mantissa to 0.00. It is now available for use in some other channel, if desired.

In operation, the setpoint relay will not be energized until the pressure is below the setpoint trigger level. At this point, the normally-open contacts will close and the number of the active setpoint will appear on the display, even if it is not assigned to the channel being displayed. The setpoint relay will remain energized until the pressure is greater than the hysteresis pressure level. At this point, the normally-open contacts will open and the setpoint number on the display will be turned off.



WARNING

Any external wiring must conform to all applicable building and electrical codes to reduce the risk of shock and fire hazards.



CAUTION

The contacts are gold-flashed making them suitable for logic level switching; however, application of AC or DC voltages greater than 20V or 20VA will cause erosion of the gold, even in just one switching cycle.



NOTE

Varian cannot guarantee compliance with FCC regulations for radiated emissions unless all external wiring is shielded, with the shield being terminated to the metal shroud on the D-sub connector. The cable should be secured to the connector with screws.

APPENDIX H

Capacitance Diaphragm Board – Part No. L6491301

DESCRIPTION

The Capacitance Diaphragm Gauge Controller (CDG) Board is designed to operate standard and temperature-compensated transducers which require ± 15 volts up to 700 ma power and have an output signal of 0 to 10 V DC. Its pressure range (full scale) is selectable at 0.1, 1, 2, 10, 100, and 1000 Torr. Each board is capable of controlling two transducers, and up to two CDG boards may be installed in the Multi-Gauge for a total of up to four CDG transducers.

Since the total available output power of the board is 750 ma for each polarity, care should be taken to be sure that the power requirements of the transducers chosen for each board do not exceed that limit, so as to avoid power overload errors. This is only an issue with a few of the heated transducers which operate at 45 degrees C and above. Even in such cases, a combination of one high power and one unheated transducer per board, or two medium power heated transducers per board, is permissible.

The CDG board can be installed in any one of the five slots in the Multi-Gauge unit; however, since it is a “high-profile” board, Varian recommends that it be put into one of the three right-hand slots, as viewed from the front of the unit, for maximum flexibility. After installation, the [CDG] label should be placed on the area provided at the rear of the unit to identify the board after the cover is installed.

THEORY OF OPERATION

Capacitance Diaphragm Gauges measure pressure by detecting the change in capacitance between two diaphragms which deflect due to a pressure differential. They are extremely accurate (0.1 to 1 percent typical), and they measure true pressure (force per unit area) regardless of gas mixture. Full scale pressures of from 0.1 to 1000 Torr are available. These ranges are considered as maximum obtainable, and at the far end of the range achieve tight accuracy only for short periods of time due to drift and repeatability errors. Accuracy loss at the far end of the range is mostly due to temperature variations, and is compensated in extended range transducers by heating the sensor to between 35 and 75 degrees C. An added benefit of a heated sensor is reduced condensation in the transducer; however, the heated sensor requires a longer warmup period to stabilize; venting the system will cool the sensor and require restabilization unless an isolation valve is used.

SPECIFICATIONS

Software required	Revision P2.1 or later
Input	0 to 10 VDC \pm 500 mV.
Impedance	10K ohms
Accuracy	Display readout within \pm 0.2 percent of reading or 0.001 percent of full-scale, whichever is greater, of input signal. (No zero offset.)
Recorder output	Buffered transducer output. Into greater than 2K ohms (RL), accuracy = \pm (0.5 percent + 0.0025 percent full scale), – (10,000/RL). Available at the transducer connectors.
Fault detection	Over range, power fault, negative input, over temperature, power supply short circuit, and over voltage protected.

Appendix M

Power supply	Bipolar 15 VDC +5 percent –3 percent; 750 ma max. per board, 700 ma max. per transducer.
Cable lengths	Standard cables (lengths of 10, 25, 50, 75, and 100 feet) are available. At the rear of the board, the top connector is “CDG-A” and the bottom is “CDG-B” (9-pin D-sub plug).



NOTE

Cable shield should not connect at the transducer end of the cable.

The pin-outs of the cable are as follows:

- 1 CDG(+)
- 2 RECORDER OUT
- 3 +15 V
- 4 +15 V
- 5 –15 V
- 6 –15 V
- 7 RECORDER GND
- 8 CDG(–)
- 9 POWER GND

(The top connector is CDG-A; the bottom connector is CDG-B)

Refer to the specific CDG head manufacturer’s instruction manual for color codes of the cable.

OPERATION

The correct software ROM must be installed in the Multi-Gauge basic unit (see instructions provided with Multi-Gauge software upgrade kit). With the board(s) installed, when the basic unit power is turned on, it will indicate the presence of a CDG board by lighting the blue (AUX) annunciator when the channel into which the board is plugged is selected with the CHAN key. For CDG-1A, AUX and 1 will light. Pressing the CHAN button will cycle through CDG-1B (AUX and flashing 1), and then (if another CDG board is installed in the next slot) CDG-2A, then CDG-2B (again flashing).

The VAC button acts as a ZERO adjust (see calibration note). The range of input for which this function works is intentionally limited to ± 400 mV, and will make the display read zero for the voltage that is there when the VAC button is pressed. Note that although the display may show 0.00, it is possible to have an offset that is below the display resolution. Pressing the VAC button will cause the display to blank and then reappear. If Multi-Gauge was able to zero the input, the display will now show “0.00”. It is recommended to let the transducer stabilize and calibrate it first, before entering any calibration factors in the Multi-Gauge. (See transducer manual for recommended stabilization period.) The calibration factor defaults to zero with a reset. The best accuracy and resolution is available by doing the bulk of the ZERO adjustment at the transducer. Changing the CDG range will cancel any internal offset.

In general, the pressure must be lowered to $\approx 1/10$ of the CDG head's lowest measureable pressure when zeroing. The default CDG range is 10 Torr. Pressing the F button and then the SET PT/SENS button will access the Range Select. This will flash a number (scientific notation), for example 1.00+1. This would mean that the full scale range is set to 10 Torr. Pressing the up and down arrow keys will cycle the ranges through 0.1, 1, 2, 10, 100, and 1000 Torr. Changing the range selected will cancel any previous zero settings, therefore the unit must be re-zeroed by pressing the VAC button.

At the completion of setting the full scale range, the display will flash a number indicating total decades of display range. The Multi-Gauge default is 5.0; however, this value should be set correctly for the transducer used. If set too high, it will be difficult to zero the transducer; if set too low, usable range will be lost. Use the UP or DOWN arrow keys to set the appropriate value. The following table lists the appropriate value for Varian transducers; for other transducers, consult the manufacturer's specifications.

Varian CeramiCel	4 decades
MKS's Baratron	4 decades

Maximum	Minimum (Resolution Limit)
1000 Torr	.1 Torr (100 mTorr)
100 Torr	.01 Torr (10 mTorr)
10 Torr	.001 Torr (1 mTorr)
1 Torr	.0001 Torr (.1 mTorr)

Error codes for this board include E11 (CDG POWER BAD), E12 (negative input within VAC range), E15 (negative input out of VAC range), E09 (over range), and E07 (over temperature). Note that E11 will latch if any of the CDG power supplies are overloaded for more than about one second, and will require either a keypad reset function or a Multi-Gauge basic unit POWER OFF/ON to clear and restore power.

Should the CDG input voltage go slightly over range, the display numbers will flash. If the CDG input goes under range (negative), the display will flash (- - -) to about $-0.5V$, and then display E15 (under range).

Other functions not fully described here are explained in the Multi-Gauge basic unit manual (6999-08-091).

NOTE

Zero Procedure

After the CDG has been installed and power has been applied for two to three hours one can begin to zero the gauge. It must be noted, in order to zero out the head, the pressure in the vacuum system must be least or less than an order of magnitude beyond the resolution of the CDG. To illustrate this; a 1 Torr full scale CDG, the lowest attainable reading is 1mTorr, in order to zero this gauge the pressure in the system must be at least $1E-4$ to $5E-5$ Torr. After stabilization in high vacuum, the zero pot on the CDG can be adjusted for a 0.000 mVDC reading. Let the CDG stabilize and press the VAC button and a 0.00 reading should be noticed. The CDG is now zeroed.

APPENDIX J

Convectron Board

DESCRIPTION

The Convectron Printed Circuit Control Board, when used with a Multi-Gauge unit, contains all the circuitry required to operate four Convectron® 275-type gauge tubes. It can be installed in any one of the five slots in the Multi-Gauge basic unit. After installation, the “CONV” label should be placed on the area provided at the rear of the unit to help in identifying the board after the cover is installed. Up to two Convectron boards may be installed for a total of eight available Convectron tubes.

Because the Convectron board uses the same “TC” display annunciators as the Thermocouple (TC) Board (Varian part number L6430301), the combination of Convectron and TC boards cannot exceed two. If one of each board is installed, the display does not indicate which “TC” readings correspond to a Convectron.

SPECIFICATIONS

Software required	Revision P2.3 or later
Pressure range	760 Torr to 1×10^{-4} Torr
Cable length	Standard lengths of 10, 25, and 50 feet are available from stock. Longer lengths (up to 500 feet) are available on special order. Connections are made to the rear of the board.

<u>Cable Type</u>	<u>Part Number</u>
10-foot Quad	L6799310
25-foot Quad	L6799325
50-foot Quad	L6799350
10-foot Dual	L6799311
25-foot Dual	L6799326
50-foot Dual	L6799351

Fault Detections	E03 – No cable or open sensor; shorted sensor. E07 – Overtemperature
Recorder output	0 to 7V linear (1 volt per decade); see Figure 1 for connections of user-supplied wiring. Varian recommends the use of shielded wiring to maintain compliance with FCC regulations for radiated emissions. The recorder output reflects ATM and VAC settings.

OPERATION

Multi-Gauge will indicate the presence of the Convectron board by lighting the curved bar graph display. The Convectron being displayed is identified by the “TC” number just beneath the bar graph. The Convectron reading is also displayed on the main digital display when there are no blue annunciators lit. Multi-Gauge also provides the capability to select any one of the installed TCs on the bar graph

simultaneously with a main ion gauge, such as a UHV or Bayard-Alpert gauge, by using the up or down arrows. This will cause the TC identifier to scroll through the installed Convectorons.

Signal	Pin No.
TC1 rec out	3
TC1 rec gnd/sld	20
TC2 rec out	10
TC2 rec gnd/sld	24
TC3 rec out	15
TC3 rec gnd/sld	27
TC4 rec out	6
TC4 rec gnd/sld	31

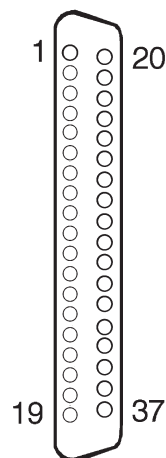

Figure 1. 37
Pin Connector

If two Convectoron boards are installed in the basic unit, Multi-Gauge will assign the identification TC1, TC2, TC3, and TC4 to the leftmost installed Convectoron board (as viewed from the front of the unit) and TC5, TC6, TC7, and TC8 to the rightmost installed board.

CONVECTRON PRINCIPLES OF OPERATION

The response of the Convectoron is affected by factors other than pressure. Normally, the tube is calibrated for nitrogen or air. If the residual gas in the vacuum system is some other gas, the pressure reading may be affected. As an example, hydrogen and helium will conduct the heat away from the tube more rapidly than air, leading to an erroneous reading which will be higher than the actual pressure. Contaminants such as oil, dust, and other chemicals can change the surface of the tube and heater which, in turn, will change the ability of the tube to dissipate the heat and affect the pressure reading.

Because the Convectoron gauge tube is a thermal response device, the ability of the tube to respond to abrupt pressure changes is limited by the mass of the sensor wire in the tube. If this combination is very small, the tube responds more rapidly than a tube with larger wire sizes.

In general, Convectoron gauge tubes are used to gain an indication of the vacuum in a system rather than an accurate measure. So many factors can affect the output of the tube that unless special care and precautions are taken, the pressure read on the control is usually accurate to within ± 30 percent of the indicated reading.

 **NOTE**

Convectoron gauge tubes should be positioned on the vacuum system so that contaminants do not collect in the tube. The tube must be mounted horizontally (see Figure 2) to prevent oil from mechanical pumps, etc. from building up in the tube, and to read pressure above 1 Torr.

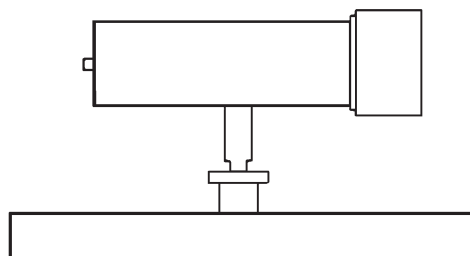

Figure 2. Mounting the Convector Tube

CALIBRATION

Before using the Convector board for pressure measurements, the operator must first set the atmosphere and vacuum readings by using the ATM and VAC keys.

- 1 Set the atmosphere reading by selecting the desired Convector tube using the CHAN key. Make sure that the tube is exposed to atmospheric pressure. Press the ATM key. The main display will read 760 Torr, or the equivalent in mBar or Pascal, as desired.
- 2 Set the vacuum reading by selecting the desired Convector using the CHAN key. Expose the selected Convector to a vacuum level lower than 10^{-4} Torr or mBar (10^{-2} Pascal). Press the VAC key. The display will read 1.0×10^{-4} Torr. The Convector tube is now calibrated.



NOTE

- If the tube has been at atmosphere and readings in the 10^{-4} Torr range are required, the tube must be exposed to vacuum (less than 10^{-4}) for at least 15 minutes and calibrated to vacuum through the preceding steps. Readings through the 10^{-4} Torr range will then be possible.
- Since the Multi-Gauge will calibrate the Convector to any ATM or VAC setting, the user is responsible for applying these functions accurately.

AUTO TURN-ON

Using a Convector board in conjunction with an ion gauge board allows the user to program a Convector to automatically turn on emission for an ion gauge. The Auto-On feature allows programming of the turn-on level between 1×10^{-3} Torr and 5×10^{-3} in Torr or mBar units (1×10^{-1} to 5×10^{-1} in Pascal) for all Varian ion gauges. The Varian 564 and 580 Broad Range Bayard-Alpert gauges can also be set to turn on between 1×10^{-2} and 5×10^{-2} Torr or mBar (1×100 and 5×100 Pascal).

Programming Auto-On

- 1 Use the CHAN key to select the ion gauge desired to automatically turn on.
- 2 Press the AUTO-ON key. The red SELECT AUTO-ON annunciators will light along with the number of the first available Convector or the number of a previously assigned Convector. The main display will show a pressure setting if assigned or 0.00 mantissa if not assigned. Pressing AUTO-ON again will select the next available Convector or exit to the pressure display.

- 3 Once the desired Convector is selected, set the actual turn-on pressure by changing the flashing digit values according to the “digit setting” procedure described in the Multi-Gauge Controller manual 6999-08-091. To cancel the Auto turn-on, set the mantissa to 0.00. Once all flashing digits are set, AUTO-TURN ON programming is complete.
- 4 When the Auto Turn-On is enabled for a given ion gauge, the EMIS key can still be used to turn off the ion gauge. Turning off the ion gauge with the EMIS key will disable the Auto Turn-On setting and requires the user to enter the Auto-On programming routine to re-activate the Auto-On setting.



NOTE

Every Convector is available as a turn-on source, regardless of whether it has a setpoint assigned to it or whether it has been assigned to turn on another ion gauge.

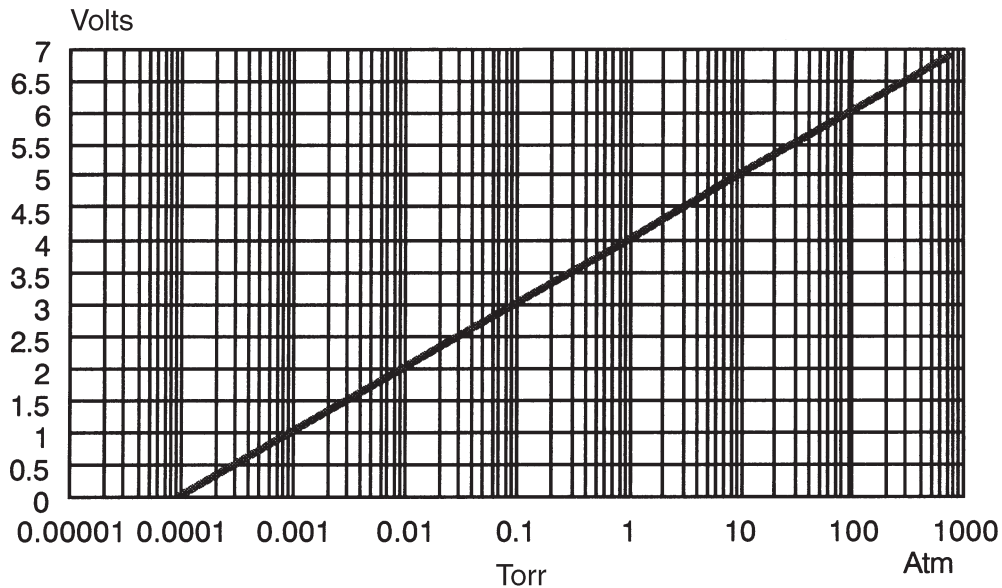

Figure 3. Granville Phillips/275 Convector with Multi-Gauge Recorder Output

APPENDIX K

Inverted Magnetron Board – Part No. L9066301

DESCRIPTION

The Multi-Gauge Inverted Magnetron Board is designed to operate the Varian Inverted Magnetron Gauge (IMG) with cable lengths of up to 100 feet. Its operating voltage is +3 kV and its nominal sensitivity is 1 ampere/Torr. The use of software linearization and dynamic power modulation allows a useful range of 1×10^{-3} to 1×10^{-11} Torr.

WARNING

Inverted Magnetron Gauges require the use of a **high voltage** source which can be **lethal**. Proper grounding of the Multi-Gauge unit and the gauge head are necessary. **Use extreme caution** when working with these instruments; the instrument must be operated only by properly trained personnel. **Do not operate the multi-gauge with the cover off.** Ensure that the ground wire on the gauge cable is properly attached to the rear panel grounding post on the Multi-Gauge

The IMG board can be installed in any one of the five slots in the Multi-Gauge unit; however, since it is a “high-profile” board, Varian recommends that it be put into one of the three right-hand slots, as viewed from the front of the unit, for maximum flexibility. After installation, the [IMG] label should be placed on the area provided at the rear of the unit to help in identifying the card after the cover is installed.

SPECIFICATIONS

EEPROM Required	Revision P3.1 or later for standard and RS-232 Models. Revision A1.7 or later for RS-422/485 models
Electrometer Accuracy	$>10^{-6}$ Torr \pm 5 percent of ion current reading (ion current = $>5 \mu\text{A}$)
Overpressure Protection	Automatic gauge tube turn-off when pressure equals or exceeds 2×10^{-2} Torr.
Recorder Output	1V/decade log-linear output (two-conductor Micro Jax connector plug supplied with board). Recorder output reflects changes in sensitivity and gas correction factors.
Fault Detections	No ion current; power supply error; overcurrent/cable short; overtemperature shutdown – gauge power shuts off when internal temperature reaches 65°C . The error codes are listed in the Multi-Gauge basic unit manual, Section 4-3.
Cable Length	Standard cables with lengths of 10 and 20 feet are available from stock. Longer cables (up to 100 feet long) are available on special order. Connections are made at the rear of the card as shown in Figure 1.
Sensitivity	Set to 1 ampere per Torr as a default, can be set from 0.1 to 99.9 amperes per Torr through the keypad second function F SENS.

Gas Correction

Set to 1.00 (N₂) as a default, can be set from 0.01 to 9.99 through the keypad second function F GAS CORR. See Appendix A for the Gas Correction Factor Table.

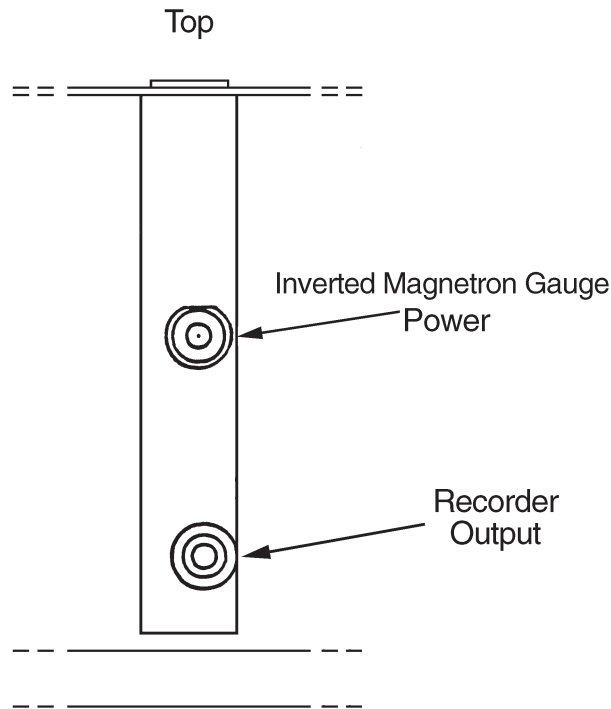

Figure 1. Card Connections



NOTE

Measurements in the high vacuum range may be inaccurate or impossible due to increased leakage currents and other effects due to long cable lengths. It is recommended that low-capacitance cable be used and that it be rigidly mounted to avoid triboelectric and leakage effects.

THEORY OF OPERATION

The inverted magnetron gauge is often used in ultra-high vacuum applications that are unsuitable for hot filament vacuum gauges due to process chemistry or high ambient x-ray levels. The operating principle of the IMG is similar to a magnetron cold cathode gauge, in that ions are trapped by a high voltage electromagnetic field and collected at an electrode. Ionization in the gauge cavity is initiated by a cosmic rays or stray radioactivity striking the electrodes to release secondary electrons. These secondary electrons strike ambient gas molecules, creating positive ions. The electrons released as a result of these collisions propagate additional ionization due to their long helical paths in the gauge's magnetic field.

In contrast to the traditional magnetron cold cathode design, the IMG anode is a rod centered and aligned along the longitudinal axis of the gauge. A potential of approximately 3 kV is generated between the anode and the cylindrical cathode, which collects ions. The IMG design addresses the

main drawback of the cold cathode gauge; the inability to start discharge at low pressures. The Varian IMG has demonstrated starts as low as 10^{-9} Torr.

The Multi-Gauge Inverted Magnetron Control Board allows readings from 1×10^{-3} Torr to 5×10^{-11} Torr. The ion current collected at the cathode is proportional to pressure such that the nominal gauge sensitivity is 3 Ampere/Torr.

GAUGE TUBE POSITIONING

The gauge tube will operate in any orientation. However, to minimize accumulation of contamination, the preferred orientation is port pointing down. The user must keep in mind that there is a strong magnetic field around the tube; therefore, when near other magnetic material, the tube must be handled with great care. Measurements in the high vacuum range may be inaccurate or impossible due to increased leakage currents and other effects due to long cable lengths. It is recommended that low-capacitance cable be used and that it be rigidly mounted to avoid triboelectric and leakage effects.

References

- 1 Dushman, S., Lafferty, J.M., SCIENTIFIC FOUNDATIONS OF VACUUM TECHNIQUE, John Wiley & Sons, Inc., Second Edition, New York, 1962
- 2 Guthrie, A., VACUUM TECHNOLOGY, John Wiley & Sons, Inc., 1963
- 3 Lewin, G., VACUUM SCIENCE AND TECHNOLOGY, McGraw-Hill, New York, 1965
- 4 Redhead, P.A. et al, ULTRAHIGH VACUUM, Chapman and Hall, London, 1968.

CALIBRATION AND ADJUSTMENTS

None; the system automatically self-calibrates in use to compensate for component variations with temperature and time.

INVERTED MAGNETRON BOARD OPERATION

Multi-Gauge will indicate the presence of an Inverted Magnetron Gauge card by lighting the blue [CC] annunciator when the channel into which the card is plugged is selected via the CHAN key. Upon initial power up, the main display will show OFF, indicating that the gauge is not measuring pressure.

To measure pressure:

When the cable and gauge head are properly connected and the [CC] annunciator is lit, pressing EMIS will toggle the high voltage source and as soon as a valid pressure measurement is available, it will be displayed.

If the current measurement is zero, the Multi-Gauge will assume first that the pressure is near the under pressure limit and that there is difficulty in starting the gauge. Hyphens [- - -] will be displayed for approximately 30 seconds while attempting to fire the gauge. If no gauge current is sensed after that time, the display will show an error code of E13 (insufficient signal) and shut off. This might also indicate an open cable.

If the pressure drops below 1×10^{-11} Torr after the initial start-up period, the gauge will shut off with an error code of E12 (under pressure). Any setpoints assigned to that cold cathode will de-energize and the fault must be cleared before the cold cathode can be re-started.

If the ion current is excessively high, either E09 (over pressure) or E04 (over current) may be displayed, a possible indication of a shorted cable or excessive gauge contamination.

Other possible error codes are E07 (over temperature) and E11 (power supply error).

To stop measuring pressure:

Simply press the EMIS button. The red EMIS annunciator will go out and the main display will show OFF to indicate that the gauge has been shut off. (Pressing the EMIS button will also remove any error messages from the display allowing the operator to retry emission if desired.)

RECORDER OUTPUT

To use the recorder output feature, assemble a cable to the Micro Jax plug supplied with the Cold Cathode Board. Varian strongly recommends using a coaxial cable to maintain compliance with FCC regulations. Refer to Figure 2 for instructions on assembling the cable.

Any recorder with an input impedance greater than 2,000 ohms and which has a full scale input range of +10V can be used. Figure 3 shows the 1 volt/decade recorder output characteristics. The recorder output reflects the reading on the display and does not require adjustments to compensate for different sensitivity settings. When the gauge is off, the output is 0 volts.

OPERATION AT HIGH PRESSURE

If the gauge is left on for a few hours in the pressure range of 10^{-3} to 10^{-2} Torr, cathode sputtering may require frequent recalibration and maintenance. This problem is not severe for short periods of operation.

Rapid venting of the tube to atmosphere will not cause damage to the tube or gauge control. The gauge tube discharge will extinguish at a pressure of 2×10^{-2} Torr. Exposure of the gauge tube to atmospheric pressure with the control on will not be harmful to the tube.

STARTING AT LOW PRESSURE

When the gauge has been off for a period of time with the system pressure of 10^{-9} Torr or lower, delayed starting may occur. This "no-strike" condition is caused by the lower probability (at the lower pressure) of ionizing enough atoms and/or molecules to obtain the starting glow discharge condition. The indications for this are an off-scale [- - -] reading on the display. This need not be a problem in systems which are periodically cycled to air, since the gauge can be turned on in the higher pressure portion of the cycle. Once started, the gauge will not extinguish at any pressure within its operating range. If a "no-strike" condition persists for more than a few minutes, the gauge can be started by increasing the pressure in the system.

GAUGE TUBE MAINTENANCE

The gauge tube may require periodic maintenance. Not powering/operating the gauge for sustained periods of time or exposing it to system contaminants (pump oil, for example) can be a source of trouble. These conditions will cause gases to be absorbed into the metal surfaces of the gauge tube, thus causing faulty readings and slow starting. Also, a buildup of contaminants will cause faulty or erratic readings.

One method of “cleaning up” the gauge tube is to apply heat to the gauge. This process drives the absorbed gases off the walls and surfaces of the gauge. The Inverted Magnetron Gauge tube is bakeable to 250°C assuming the connection to the vacuum system is also bakeable. (Varian cable L9064 is bakeable to 250°C)

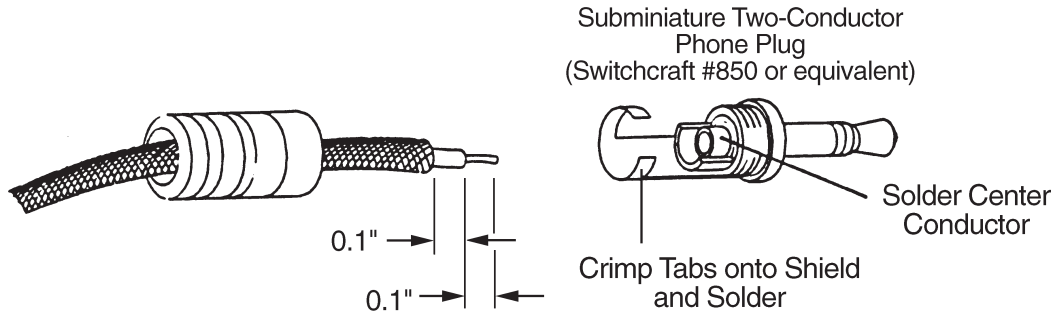

Figure 2. Assembling the Recorder Output Cable/Plug

Note: See page B-5 for algorithm for voltage to pressure conversion.

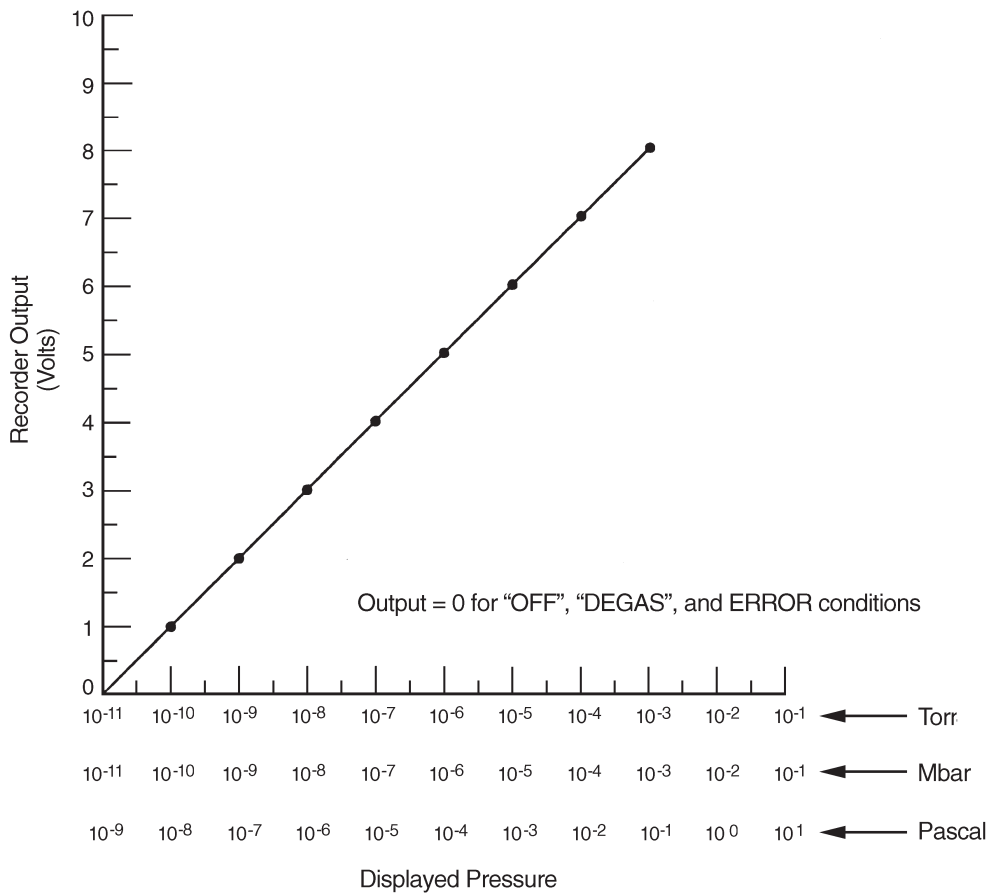

Figure 3. Recorder Output Characteristics

Appendix K

For best results and for removing built-up contaminants, a thorough cleaning of the gauge tube is necessary. Both the anode and the cathode surfaces must be cleaned. This can be accomplished by disassembling the gauge and cleaning each part. A wire brush, steel wool, or emery cloth are good surface cleaners. After brushing, the parts must be washed in soap and water (preferably Alconox), rinsed in plain water, a final rinse in alcohol, then hot-air dried if possible.

Internal parts which are damaged or excessively contaminated may be replaced by ordering the Inverted Magnetron Maintenance Kit from Varian (part number R0040301)

Appendix K

TROUBLESHOOTING

<i>Fault</i>	<i>Possible Cause/Remedy</i>
Gauge control does not read above 1×10^{-11} Torr – E03	Check high voltage cable connection at tube and rear of control.
Gauge control reads E09 (over pressure) even when pressure is below 1×10^{-2} Torr	Check high voltage cable for a short to the center conductor. Inspect gauge tube for a low resistance from cathode to body. Insulator may be damaged.
Gauge tube won't strike a discharge	a. Check the green LED mounted on the top side of the cold cathode board (visible without removing the basic unit cover). If it is lit, the high voltage power supply is working.
	b. Check high voltage cable for continuity.
	c. The system pressure may be too low (E13) for the gauge tube to strike.
Reading on gauge control is erratic	Gauge tube is contaminated. Follow procedure for disassembly and cleaning of tube.

APPENDIX L

ConvecTorr Board – Part No. L9887301

DESCRIPTION

The ConvecTorr Printed Circuit Control Board, when used with a MultiGauge unit, contains all the circuitry required to operate two ConvecTorr gauge tubes. It can be installed in any one of the five slots in the MultiGauge basic unit. After installation, the TC label should be placed on the area provided to help in identifying the card after the cover is installed. Up to two ConvecTorr cards may be installed for a total of four available ConvecTorr gauges.

SPECIFICATIONS

EEPROM required	Revision P3.1 or later for standard and RS-232 Models. Revision A1.7 or later for RS-422/485 models
Software requirement	3.1 or higher
Range	760 Torr to 1 mTorr
Response	10 msec typical
Accuracy	±10% or 1 mTorr or which ever is greater (typical)
Recorder output	log/linear 1-7 VDC
Cable lengths	Standard lengths available – 10, 25, 50, 75 and 100 ft. Custom lengths are also available
Fault Detection	E03, no cable connection, possible open circuit for heater or thermocouple junction on the ConvecTorr gauge tube

OPERATION

The MultiGauge will indicate the presence of the ConvecTorr card by lighting the curved bar graph display. The ConvecTorr being displayed is identified by the “TC” number just beneath the bar graph. The ConvecTorr reading is also displayed on the main digital display when there are no blue enunciators lit. MultiGauge also provides the capability to select any one of the installed TCs on the bar graph simultaneously with a main ion gauge, such as a UHV or Bayard-Alpert gauge, by using the up or down arrows. This will cause the TC identifier to scroll through the installed ConvecTorr gauges. If two ConvecTorr cards are installed in the basic unit, MultiGauge will assign the identification TC1 and TC2 to the leftmost installed ConvecTorr card (as viewed from the front of the unit) and TC3 and TC4 to the rightmost installed card.

PRINCIPLE OF OPERATION

Traditional Thermocouple Theory A thermocouple operates on the principle that, at sufficiently low pressures, the thermal conductivity of the gas decreases with a decrease in pressure. A thermocouple is attached to a heater wire in which the temperature is raised to approximately 350°C by passing a current through the wire. When constant power is maintained through the heater wire, the temperature measured by the thermocouple will change with pressure. This change is directly related to the heat conducted away by the gas in the environment. The electromotive force (emf) measured from the thermocouple is read on a scale which has been calibrated for pressure.

The ConvecTorr The design approach provides the faster-than-TC response of the pirani, while avoiding problems incurred by the a long, thin, and fragile pirani filament. The ConvecTorr circuitry measures the amount of current required to keep the thermocouple junction at a constant temperature as opposed to conventional thermocouples that measures the (output voltage) temperature of the element junction at a fixed current. Controlling and measuring the current provides a faster response time, typically .3 seconds as compared to standard thermocouples which have 1.5 second response.

The response of the ConvecTorr is also affected by factors other than pressure. Normally, the tube is calibrated for nitrogen or air. If the residual gas in the vacuum system is some other gas, the pressure reading may be affected. As an example, hydrogen and helium (lighter weight gases) will conduct the heat away from the thermocouple more rapidly than air, leading to an erroneous reading which will be higher than the actual pressure. Heavier weight gas compositions like argon will conduct heat away at a slower rate thus indicating a lower pressure than the actual pressure. Contaminants such as oil, dust, and other chemicals can change the surface of the thermocouple and heater which, in turn, will change the ability of the thermocouple junction to dissipate the heat and affect the pressure reading.

ConvecTorr gauge tubes should be positioned on the vacuum system so that contaminants do not collect in the tube. Preferably, the tube port should be oriented down to prevent oil from mechanical pumps, etc. from building up in the tube.

CALIBRATION

Before using the ConvecTorr card for pressure measurements, the operator must first set the atmosphere and vacuum readings by using the ATM and VAC keys. Set the atmosphere reading by selecting the desired thermocouple using the CHAN key. Make sure that the ConvecTorr gauge tube is exposed to atmospheric pressure. Press the ATM key. The main display will read 760 Torr, or the equivalent in mbar or Pascal, as desired.

Set the vacuum reading by selecting the desired ConvecTorr gauge tube using the CHAN key. Expose the selected ConvecTorr gauge tube to a known vacuum level as high as 9.9×10^{-2} Torr or mbar (9.9×100 Pascal) or to a vacuum level lower than 10^{-3} Torr or mbar (10^{-1} Pascal). Press the VAC key. The display will show the most recent vacuum setting (initially 1.0×10^{-3} Torr) with the most significant digit flashing. Using the standard 'digit setting' procedure described in the MultiGauge Controller manual (699908091), set the display to the vacuum level desired to calibrate the ConvecTorr gauge tube. The ConvecTorr gauge tube is now calibrated.

AUTO TURN-ON

Using a ConvecTorr card in conjunction with an ion gauge card allows the user to program a ConvecTorr to automatically turn on emission for an ion gauge. The Auto-On feature allows programming of the turn-on level between 1×10^{-3} Torr and 5×10^{-3} in Torr or mbar units (1×10^{-1} to 5×10^{-1} in Pascal) for all Varian ion gauges. The Varian 564 Broad Range Bayard-Alpert gauge can also be set to turn on between 1×10^{-2} and 5×10^{-2} Torr or mbar (1×100 and 5×100 Pascal).

Programming Auto-On

- Use the CHAN key to select the ion gauge desired to automatically turn on.
- Press the AUTO-ON key. The red SELECT AUTO-ON enunciators will light along with the number of the first available thermocouple or the number of a previously assigned thermocouple. The main display will show a pressure setting if assigned or 0.00 mantissa if not assigned. Pressing AUTO-ON again will select the next available thermocouple or exit to the pressure display.
- Once the desired thermocouple is selected, set the actual turn-on pressure by changing the flashing digit values according to the “digit setting” procedure described in the MultiGauge Controller manual 699908091. To cancel the Auto turn-on, set the mantissa to 0.00. Once all flashing digits are set, AUTO-TURN ON programming is complete.
- When the Auto Turn-On is enabled for a given ion gauge, the EMIS key can still be used to turn off the ion gauge. Turning off the ion gauge with the EMIS key will disable the Auto Turn-On setting and requires the user to enter the Auto-On programming routine to re-activate the Auto-On setting.

 **NOTE**

- Since the MultiGauge will calibrate the thermocouple to any ATM or VAC setting, the user is responsible for applying these functions accurately.
- Every thermocouple is available as a turn-on source, regardless of whether it has a setpoint assigned to it or whether it has been assigned to turn on another ion gauge.

Recorder Output: (2) 9 pin D-Sub connectors

	Rec (+)	Rec (-)
ConvecTorr 1 (top 9 pin)	7	8
ConvecTorr 2 (bot. 9 pin)	7	8

Algorithm: Convert recorder output voltage to pressure

To calculate the pressure from the voltage output

Example: recorder output = 3.28 volts DC

To get the exponent, take the integer part of voltage output which is 3 and subtract 4:

$$3 - 4 = -1 \text{ (E-1)}$$

Now to find the mantissa, take the fractional portion and add .1 to it and divide by .11

$$(0.28 + .1) / 0.11 = 3.45$$

Therefore:

$$3.28 \text{ VDC} = 3.45 \text{ E-1 Torr}$$

User-supplied wiring

Varian recommends the use of shielded wiring to maintain compliance with FCC regulations for radiated emissions.

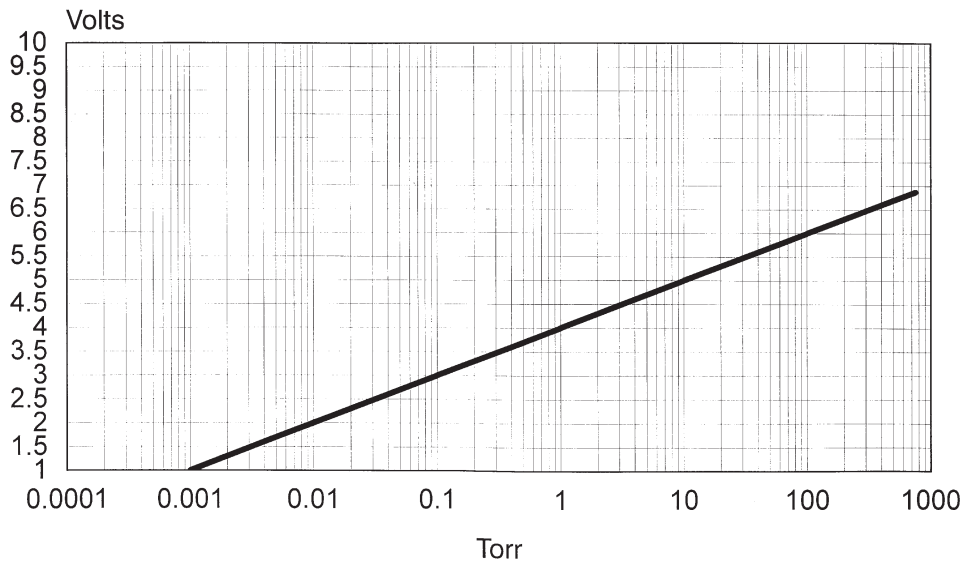

Figure 1. Multi-Gauge Convectorr Recorder Output

APPENDIX M

RS232 and RS485/422 Boards and ASCII Protocol Option

Part No. L6439301 (RS232 Interface), Part No. L6449301 (Fiber Optic RS232 Interface)

Part No. L8940301 (RS485/422 Interface)

The Varian ASCII protocol applies to both the RS232 option and the RS485/422 option. Software version Ax.x is required.

RS232 DESCRIPTION

Two RS232 interface options are available for Multi-Gauge; a standard EIA-232 hardware compatible interface and a Fiber Optic interface. Both of these printed circuit board options plug into the dedicated digital communications interface slot (J3) on the basic unit motherboard, though only one can be installed at a time.

The RS232 board contains two DIP switches so that the board can be configured for different revisions of the motherboard and to perform a “null modem” function; i.e., swapping the Rxd, Txd, CTS, and RTS connections. These settings should be made before the board is installed into the basic unit. The factory settings are for the latest revision motherboard and to act as a null modem. Refer to Tables 1 and 2 for settings.

The fiber optic board uses a Hewlett-Packard HFBR-2502/1502 receiver and transmitter pair to implement a low cost fiber link. This is useful in electrically noisy environments, to eliminate ground loops, or when the Multi-Gauge unit must be at a different voltage potential than the host computer (for example, high-energy physics applications).

Table 1. Connections

Connections	S1-1	S1-2	S1-3	S1-4	S1-5	S1-6	S1-7	S1-8	
RTS at pin 7 CTS at pin 8	CL	OP	CL	OP					NULL
RTS at pin 8 CTS at pin 7	OP	CL	OP	CL					STRAIGHT
Txd at pin 3 Rxd at pin 2					CL	OP	CL	OP	NULL
Txd at pin 2 Rxd at pin 3					OP	CL	OP	CL	STRAIGHT

Table 2. Motherboard Revisions

Revision	S2-1	S2-2	S2-3	S2-4
“V” or earlier	OP	OP	OP	OP
“W” or later	CL	CL	CL	CL

For switches labeled ON or OFF – CL = ON
OP = OFF

NOTE

Revision “V” or earlier motherboards can be easily identified by the presence of a black box mounted near the power entry connector of the basic unit and attached by Velcro to a capacitor on the motherboard.

RS232 INSTALLATION

After ensuring that the Multi-Gauge is turned off and the power cable disconnected, remove the top cover. Remove and save the small screws then discard the blank plastic hole cover on the rear panel. It may be necessary to remove the plug-in boards for access to connector J3 on the motherboard. Note that both option boards make use of connector J3; however, only one option can be installed at a time.

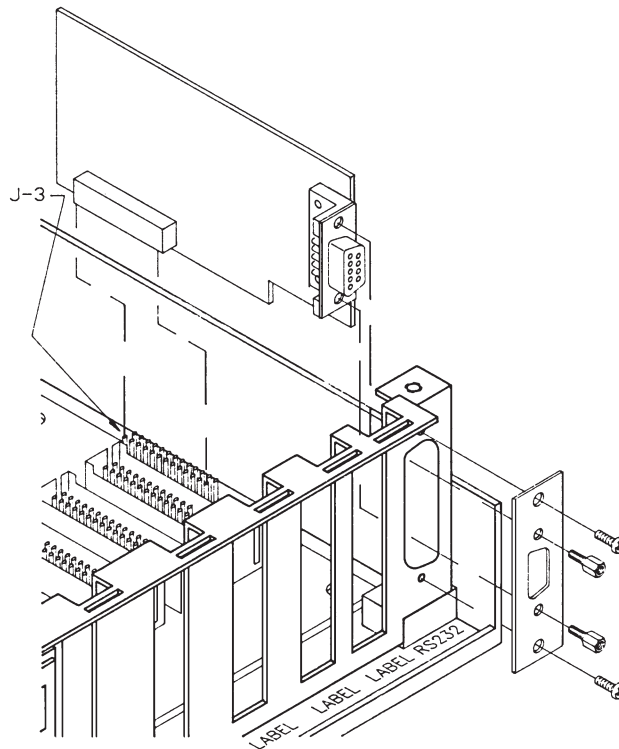

Figure 1. Cable Installation

To install the RS232 driver board, simply plug the board into connector J3, after properly setting the DIP switches, making sure that the board is mated correctly with J3 and that the 9-pin D-Sub connector is protruding through the hole in the rear panel. Attach the connector plate to the D-Sub connector using the two hex standoffs supplied with the board. Attach the plate to the rear panel with the two small screws removed earlier when removing the blank plastic hole cover.



NOTE

These boards will operate only with a Multi-Gauge Motherboard Assembly (P/N L8315301) revision S or later.

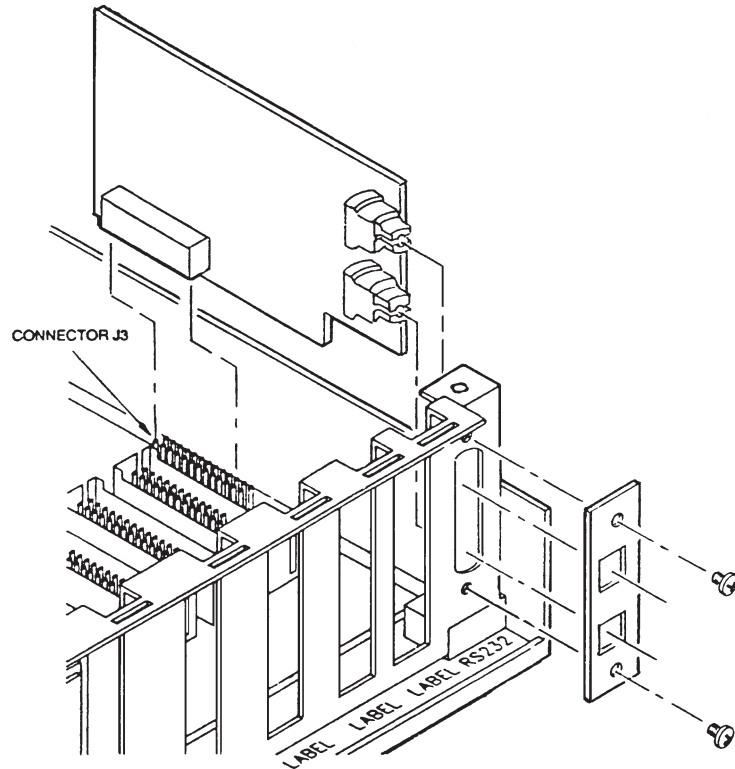

Figure 2. Installing the Fiber Optic Board

SPECIFICATIONS

RS232 DRIVER BOARD

Multi-Gauge Serial Port Signals

Pin	Signal	Description
5	Ground	
3,2	TXD	Transmitted Data – outputs serial data from the Multi-Gauge to the host RXD line.
2,3	RXD	Received Data – inputs serial data to the Multi-Gauge from the host TXD line.
7,8	RTS	[Not used.]
4	DTR	Data Terminal Ready – output signal from the Multi-Gauge. Set to logic 0 when Multi-Gauge is powered up and, therefore, ready to communicate.

Consult the instruction manual of the host computer for its serial port connections.

Multi-Gauge outputs +9V for an asserted (logic 0) level, and –9V for an unasserted (logic 1) level. The input signals to Multi-Gauge must be between +2.4V and +30V for an asserted (logic 0) level, and between +0.8V and –30V for an unasserted (logic 1) level.



NOTE

Varian cannot guarantee compliance with FCC regulations for radiated emissions unless all external wiring is shielded, with the shield being terminated to the metal shroud on the D-sub connector. The cable should be secured to the connector with screws.

Fiber Optic Board Option

The Multi-Gauge fiber optic link uses two communication lines. Refer to Figure 2.

The receiver link used is Hewlett-Packard No. HFBR-2502. It is the blue upper connector (LJ2) on the fiber optic board. The transmitter link used is Hewlett-Packard No. HFBR-1502, the gray lower connector (LJ3). The host must use this same transmitter/receiver pair. The fiber optic cable to be used is 1 mm diameter plastic fiber with standard Simplex plastic snap-in connectors. The maximum guaranteed length is 30 m using a standard attenuation cable and 41 m using an improved attenuation cable, at 25°C and with a peak transmitter drive current of 60 mA.

RS485 DESCRIPTION

This Multi-Gauge option provides serial communications capability as specified in EIA Standards 422 and 485. Both of these employ differential line drivers and receivers and are capable of communicating to distances of 4000 feet at 19,200 baud in a multi-drop scheme. The 422 mode uses separate wire pairs for transmit and receive data; 485 multiplexes transmit and receive on one pair, with the other pair available for RTS.

The user can also choose to add a differential terminating resistance of 220 ohms to the two wire pairs, if desired. The factory setting is unterminated. In addition, by connecting to either of two ground connections, the user can choose to add 100 ohms in series with his system ground to help break ground loops.

RS485 INSTALLATION

- 1 Before installing the board, set the DIP switches to select between RS422 or RS485 modes of operation (refer to the following table). The board is shipped from the factory set at RS485.

Switch Number	RS422	RS485
1	open	closed
2	closed	open
7	open	closed
8	closed	open

Open = Off Closed = On

- 2 Select the terminating resistance (the factory setting is unterminated).

Switch Number	220 ohms out	220 ohms in
3	open	closed
4	open	closed

Open = Off Closed = On

- 3 Set the board for proper revision of the mother board (the factory setting is for Revision W or later). The revision letter of the mother board in the basic unit is located at the rear of the unit and is written in a white box.

Switch Number	Rev. V or earlier	Rev. W or later
5	closed	open
6	closed	open

Open = Off Closed = On

- 4 Install the board into the leftmost connector (J3) on the mother board. The connector plate is held onto the basic unit rear panel with the two screws saved after removing the blank cover (see Figure 3). The long screw is used to anchor the board to the plate.

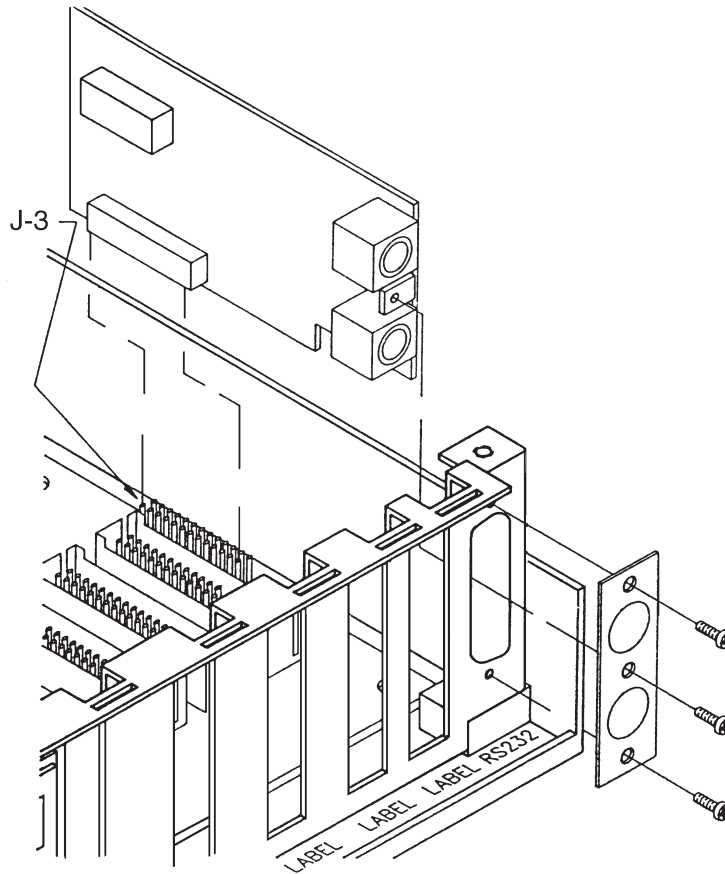

Figure 3

- 5 Change the EPROM, if necessary, so that software revision A1.0 or later is installed. Note: this option will not work with any software except "Ax.x" revisions.
- 6 There are two shielded mini DIN connectors for connections to the rest of the network. These are in parallel and permit easy "daisy chaining" of multiple units. The connections are as follows and are shown in Figure 2.

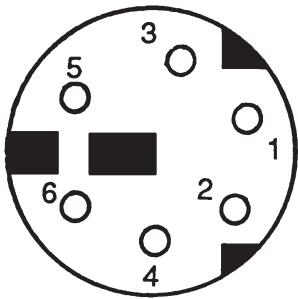

Figure 2

Pin Number	RS422	RS485	Wire Color*
1	Ground	Ground	green
2	Ground	Ground	black
3	Txd+	Xcv+	red
4	Rxd-	RTS-	brown
5	Txd-	Xcv-	blue
6	Rxd+	RTS+	white

*These colors are pre-made Cinch cable type MDC-6Pxx.



Six-pin mini-DIN connectors are available in either pre-molded cable assemblies, as indicated in the table, or as connectors which require assembly to cables by the user. Electronics distributors, such as Digi-Key, et al, can supply either. This information is not intended as an endorsement of any particular vendor but rather to give the user a starting point.

The cables used should be shielded to maintain compliance with FCC requirements for radiated emissions.

ASCII Protocol

The user's application must conform to the software protocol as specified. The unit's baud rate and address are programmed through the front panel keypad. For successful operation, all units on the network must be at the same baud rate and, to avoid contention, have a different address.

Upon receipt of the command, Multi-Gauge holds its RTS line (RS485 option only) to a logic 1 (unasserted) while it processes the command and returns any required data. If the host does not monitor its CTS line, it must limit the frequency of commands as follows.

- a If a response is expected, the host should wait to receive the response before starting the next command.
- b Command rate should be limited to one every 500 ms. Rates exceeding this limit may result in a Multi-Gauge reset.

While Multi-Gauge will tolerate high speed communications, it should be noted that the application should not tie up Multi-Gauge with incessant strings of commands in order to allow it to process pressure data from the gauge channels.

To program baud rate and address:

press the [F] key then the [kbaud] key;

the mantissa will flash with the present baud rate. Use the up/down arrows to select the desired baud rate. You may select 1.2, 2.4, 4.8, 9.6, or 19.2 kbaud.

Press the [F] key;

the exponent field will flash. Again, use the up/down arrows to select no parity, "-", odd "O", or even "E" parity.

Press the [F] key again;

(RS422/485 options only) two digits will flash, use the up/down arrows to select the desired address for the unit. You may select any address from "00" to "FF". "00" default.

Press the [F] to enter your programming.

Command/Response Format

The command format is:

“#” {MG address} {command} {dfata} {carriage return}

The response is:

“>” {optional data} {carriage return}

Multi-Gauge will send “?FF” as a response if the command or data is invalid, or if the command length is incorrect. There will be no response to a parity error, wrong address, or lack of termination character.

Command Set

All lower-case characters are place holders and must be replaced as follows:

- aa = 2 char hex bus address aa = 00 (for RS232 models)
- hh = 2 char hex byte value
- c = 1 char channel type (“I”, “T”, “A”)
 - where I = BA/UHV/CCG
 - T = TC/CONV
 - A = CDG
- n = 1 char channel number (“1” “9”)
- x = “1” “9” data value
- t = message terminator char (#13, carriage return char)

Function	Command	Response
Read MG contents	#aa01t	>hhhhhhhhht where the card id codes are: 10 = UHV Bayard-Alpert 20 = BA configured for Broad-range gauges 30 = BA configured for standard Bayard-Alpert gauges 38 = Cold cathode 3A = Inverted Magnatron 40 = TC board 42 = Granville-Phillips Convector 4C = CDG 48N = ConvecTorr 50 = Set point 60 = Remote I/O FE = Empty slot
Read pressure	#aa02cnt	>x.xxxE-xxt
Read Set Point State	#aa03T	>00hht where bits 0 – 7 represent set points 1-8 and value is state (0 = off, 1 = on)

Appendix M

Function	Command	Response
Read assigned set points	#aa04cnt	>00hht Where bits 0 – 7 represent set points 1 – 8 and value is assignment (0 = not assigned, 1 = assigned)
Read software revision	#aa05t	>hhhht where hh = 0 – 9 and the revision is hh.hh
Set pressure units to Torr	#aa10t	>t
Set pressure units to mBar	#aa11t	>t
Set pressure units to Pascal	#aa12t	>t
Read pressure units	#13t	>hht where hh = 00 is Torr hh = 01 is mBar hh = 02 is Pascal
Set key pad lock OFF	#aa20t	>t
Set keypad lock ON	#aa21t	>t
Read keypad lock status	#aa22t	>hht where hh = 00 is OFF hh = 01 is ON hh = is partial
Set Partial keypad lock	#aa23t	>t
Set Emission OFF	#aa30cnt	>t
Set Emission ON	#aa31cnt	>t
Read Emission status	#aa32cnt	>hht where hh = 00 is OFF hh = 01 is ON
Set Emission On Fil2	#aa33cnt	>t
Read Filament Lit	#aa34cnt	>hht
Set Auto fil Advance Off	#aa35t	>t
Set Auto Fil Advance On	#aa36t	>t
Read Auto Fil Advance State	#aa37t	>hht where hh = 00 is OFF hh = 01 is ON
00H is Off		
Set degas OFF	#aa40cnt	>t
Set degas ON	#aa41cnt	>t
Read degas status	#aa42cnt	>hht where hh = 00 is OFF hh = 01 is ON
Read gas correction	#aa50cnt	>x.xxxt

Appendix M

Function	Command	Response
Set gas correction	#aa51cnx.xxxt	>t
Read Emission current	#aa52cnt	>x.xxxt
Set Emission current	#aa53cnx.xxxt	>t
Read Sensitivity	#aa54cnt	>xx.xxxt
Set Sensitivity	#aa55cnxx.xxxt	>t
Read CDG full scale	#aa56cnt	>x.xE-xxxt
Set CDG full scale	#aa57cnx.xE-xxxt	>t
Read CDG number of decades of range	#aa58cnt	x.xt
Set CDG number of decades of range	#aa59cnx.xt	>t
Set Set Point pressure level	#aa6hcnx.xxxE-xxxt where h is the set point relay number, 1 – 8	>t
Set Set Point hysteresis level	#aa7hcnx.xxxE-xxxt where h is the set point relay number, 1 – 8	>t
Read Set Point pressure level	#aa8ht where h is the set point number, 1 – 8	>x.xxxE-xxxt
Read Set Point hysteresis level	#aa9ht where h is the set point number, 1 – 8	>x.xxxE-xxxt
Set TC Vac	#aaA0cnx.xE-xxxt	>t
Set TC/Convectron ATM	#aaA1cnt	>t
Set CDG Vac	#aaA2cnt	>t
Set TC Update Rate to Slow (standard)	#aaA7t	>t
Set TC Update Rate to Fast	#aaA8t	>t
Read TC Update Rate	#aaA9t	>hht hh = 00 is Slow hh = 01 is Fast
Set Auto-On	#aaB0cn1cn2x.xE-xxxt where cn ₁ is the IG channel cn ₂ is the TC channel	>t
Read Auto-On	#aaB1cnt	>cnx.xExxt
Read Pressure Dump	#aa0Ft	>x.xxxE-xx, x.xxxE-xx, . . . t The number of bytes in the response will vary with the card configuration of the unit. The order of readings is from left to right in the basic unit (looking from the front panel).

Testing, Troubleshooting and Debugging Multigaugage Serial Communication Issues

- Establish communication prior to programming
- Debugging an existing software program to determining hardware/software conflicts

The most important and first thing one must do is to establish communication. This will verify that the Multigaugage serial communication board, cable, and computer's (PC) serial port are all working.

Tips (RS232)

- Use a straight through nine pin RS232 serial communication cable (ex. Pins 2 to 2, 3 to 3, 5 to 5, etc.). One can purchase such a cable at a local computer, office supply or electronics store.
- Set the dip switch settings on the RS232 board for the straight through setting.
 - Null modem serial cable, pins 2 and 3 are swapped (i.e., Pins 2 to 3, 3 to 2) use the default null modem setting, set the correct dipswitch settings for the RS232 board.

Tips (RS422/485)

- Use the recommended pre-made Cinch cable type MDC-6 Pxx w/mini-Din connectors as stated in the manual.
- ❖ A great tool to see if communication has been established is to use terminal emulator programs and packages like "ProComm" or Windows 3.xx "Terminal" or "Hyperterminal" found in Windows 95.



NOTE

Customers with an RS422/485 Communications board can purchase an RS422/485 to a RS232 connector from a local supplier to use with a PC that does not have an RS422/485 communications port.

Terminal-Windows 3.xx (Usually found in the Accessories group)

- Settings
 - Communications
 - Baud rate (use MG default 9600)
 - Data bits-8
 - Parity-none
 - Flow control – none
- Terminal Emulation
 - DEC VT100 (ANSI)
- Terminal Preferences
 - Terminal Mode-check line wraps
 - CR-Inbound and Outbound; Check-Cursor Blink

Hyperterminal – (Windows 95/Found-Start-Programs-Accessories)

Hypertrm.exe

Connection Description

Serial Comm – Name:

Choose Icon

Phone # Screen

Go to-Connect using: Com Port (*Choose Com port #*)

- File

- Properties

- Configure:

- Bits Per Second-ex. 9600

- Data Bits-8

- Parity-None

- Stop Bit-1

- Flow Control-None

- Settings

- Emulation-Auto Detect

- ASCII Sending

- Check-Send line ends with line feeds

- ASCII Receiving

- Check-Wrap lines that exceed terminal width

Simply type in the commands given in the manual and the appropriate response will be displayed or the appropriate action will be executed.